

# Pre-Roller

- Model MRC
- Model MRD
- Model MRE/MRF
- Model MRG/MRH
- Model MRJ/MRK/MRL



Mounted on the front of the press.

Allows the die to roll from the front of the press onto the bolster.

- Loading the die

Load the die with a crane or forklift.  
Pre-Rollers set in front of press machine enable easy transfer of the die.

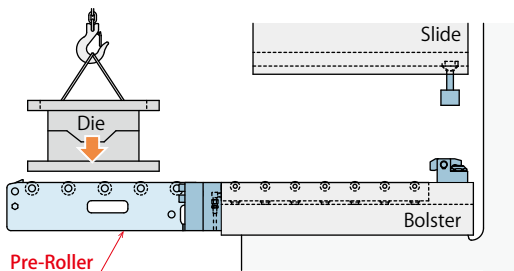

- Move the die to the bolster

Move the die to the bolster.  
Pre-Rollers and die lifters allow the die to roll onto the bolster with minimal force.

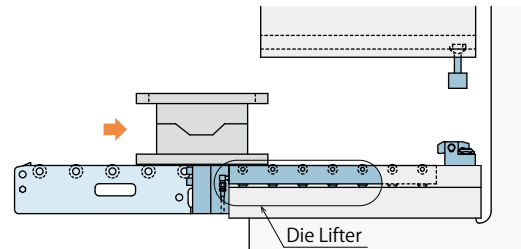

- The stopper prevents die fall.

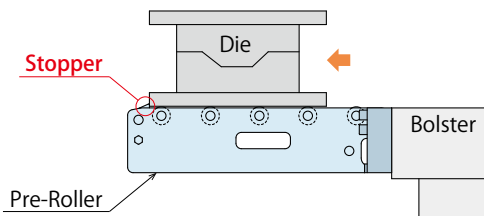

By pushing the stopper until the end, the stopper will be released.

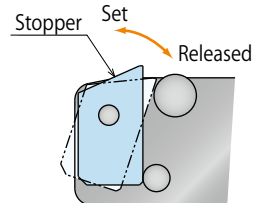

※. When using the stopper, it must be returned to set position manually.

When loading the die, the stopper is pressed down by the die weight.

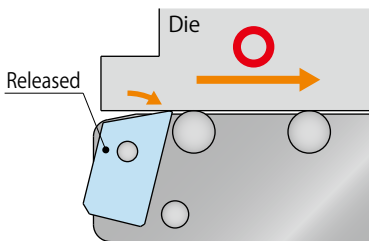

After the die passes over the stopper, it automatically goes up with the internal spring.

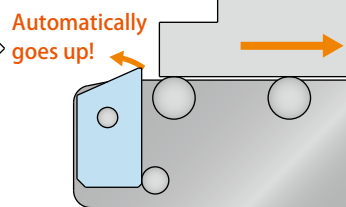

In case of reverse travel, the stopper prevents die falling.

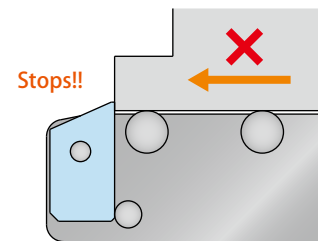

● Variations

## Five Types of Frame Storage

**Removable**  
Model MRC

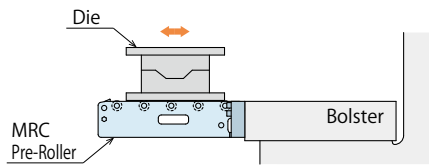

Used when loading / unloading the die.

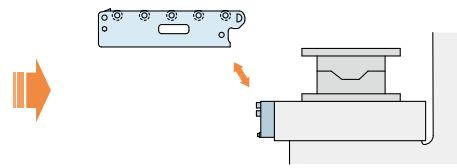

Can be removed when it is not in use.

**Removable-  
Vertical Folding**  
Model MRD

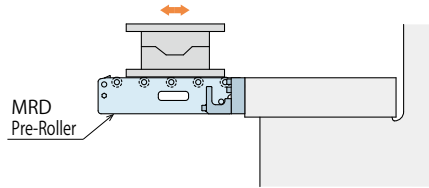

Used when loading / unloading the die.

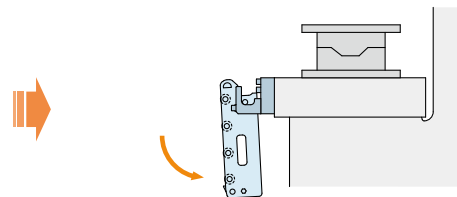

Can be removed or folded when it is not in use.

**Horizontal Folding**  
Model MRE/MRF

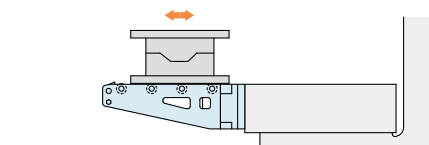

Used when loading / unloading the die.

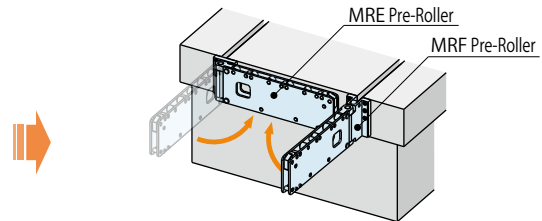

Can be folded horizontally when it is not in use.

**Removable  
with Stand**  
Model MRG

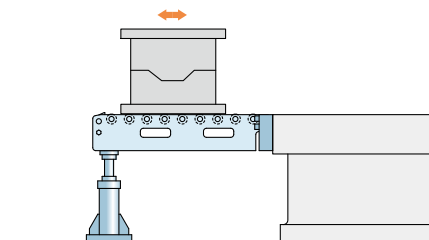

Used when loading / unloading the die.  
With stand it is suitable for heavy dies.

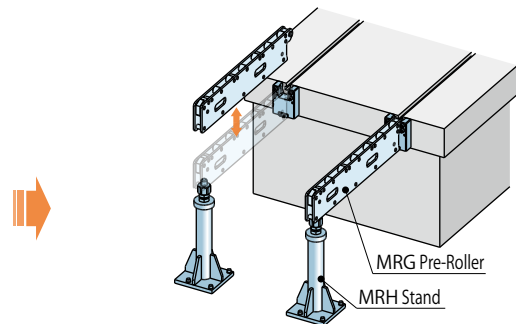

Can be removed when it is not in use.

**Horizontal Folding  
with Stand**  
Model MRJ/MRK

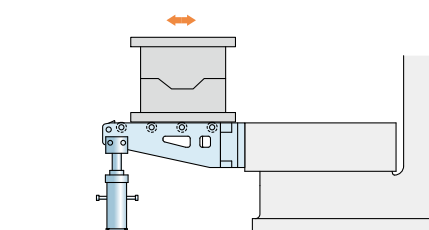

Used when loading / unloading the die.  
With stand it is suitable for heavy dies.

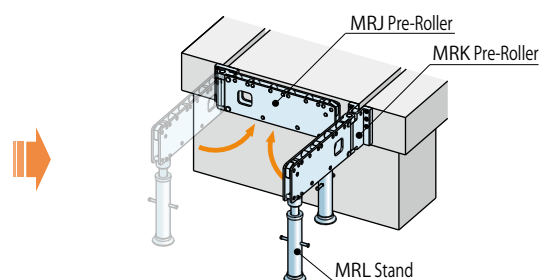

Can be folded horizontally when it is not in use.

Clamp  
Hydraulic Unit  
Operation Control Panel

Die Lifter  
Pre-Roller

Accessories

Cautions  
Company Profile

Die Lifter

RA

RB

Pre-Roller

MRC

MRD

MRE/MRF

MRG

MRJ/MRK

Model No. Indication

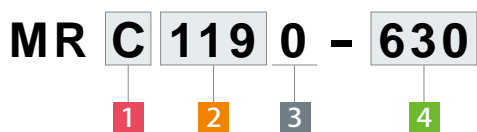

1 Frame Storage Type

- C : Removable Type ————— P.093
- D : Removable-Vertical Folding Type ————— P.103
- E : Horizontal Folding Type (Inside Arm) ————— P.113
- F : Horizontal Folding Type (Outside Arm) ————— P.113
- G : Removable Type (With Stand) ————— P.121
- J : Horizontal Folding Type (With Stand) (Inside Arm) ————— P.129
- K : Horizontal Folding Type (With Stand) (Outside Arm) ————— P.129

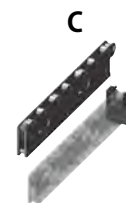

2 Mounting Block Height (Pre-Roller Height)

- 075 : Mounting Block Height 75 mm
- 119 : Mounting Block Height 119 mm
- 150 : Mounting Block Height 150 mm
- 190 : Mounting Block Height 190 mm

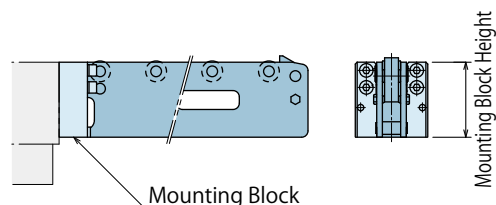

3 Design No.

- 0 : Revision Number

4 Die Travel L · Mounting Block Type

**Dimensions** : Die Travel L (Distance that the die can be pulled out)  
(Please refer to the specifications)

- B : Mounting Block

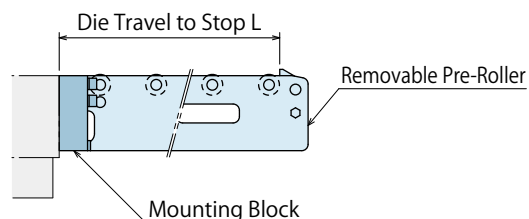

Compatible Mounting Blocks

Pre-Roller Model	Mounting Block Model	Mounting Block Weight (kg)
MRC0750-□	MRC0750-B	1.2
MRC1190-□	MRC1190-B	3.4
MRC1500-□	MRC1500-B	4.6
MRC1900-□	MRC1900-B	6.9

Note

1. MRC Pre-Roller and MRC-B Mounting Block are sold separately.  
Order by type and number required.

## Specifications

### MRC0750-□

Model	Weight (kg)	Number of Rollers	Die Travel to Stop L (mm)	Max. Loading Weight each (kg) <sup>※1</sup>	
				at Roller A	at Point B
MRC0750-200	3.0	3	200	850	1020
MRC0750-250	3.5	3	250	650	800
MRC0750-315	4.3	4	315	500	620
MRC0750-355	4.8	4	355	450	560
MRC0750-400	5.3	5	400	400	500
MRC0750-450	5.8	5	450	350	440
MRC0750-500	6.4	6	500	300	380
MRC0750-560	7.1	6	560	270	340
MRC0750-630	8.0	7	630	240	310

### MRC1190-□

Model	Weight (kg)	Number of Rollers	Die Travel to Stop L (mm)	Max. Loading Weight each (kg) <sup>※1</sup>	
				at Roller A	at Point B
MRC1190-315	6.7	3	315	1500	1840
MRC1190-355	7.6	4	355	1300	1610
MRC1190-400	8.4	4	400	1100	1370
MRC1190-450	9.4	5	450	950	1190
MRC1190-500	10.3	5	500	800	1010
MRC1190-560	11.3	6	560	700	890
MRC1190-630	12.4	6	630	650	830
MRC1190-710	14.0	7	710	500	640
MRC1190-800	15.5	7	800	450	580
MRC1190-850	16.5	8	850	400	510
MRC1190-900	17.5	8	900	350	450
MRC1190-950	18.6	9	950	300	380
MRC1190-1000	19.5	9	1000	250	320

### MRC1500-□

Model	Weight (kg)	Number of Rollers	Die Travel to Stop L (mm)	Max. Loading Weight each (kg) <sup>※1</sup>	
				at Roller A	at Point B
MRC1500-400	9.9	4	400	1500	1870
MRC1500-450	11.2	5	450	1350	1700
MRC1500-500	12.3	5	500	1200	1520
MRC1500-560	13.4	6	560	1050	1330
MRC1500-630	14.8	6	630	900	1150
MRC1500-710	16.8	7	710	800	1020
MRC1500-800	18.7	7	800	700	900
MRC1500-850	20.0	8	850	600	770
MRC1500-900	21.1	8	900	550	710
MRC1500-950	22.4	9	950	500	640
MRC1500-1000	23.5	9	1000	450	580

### MRC1900-□

Model	Weight (kg)	Number of Rollers	Die Travel to Stop L (mm)	Max. Loading Weight each (kg) <sup>※1</sup>	
				at Roller A	at Point B
MRC1900-400	11.9	4	400	2000	2500
MRC1900-450	13.4	5	450	1800	2260
MRC1900-500	14.8	5	500	1600	2020
MRC1900-560	15.9	6	560	1400	1780
MRC1900-630	17.8	6	630	1250	1600
MRC1900-710	20.2	7	710	1100	1410
MRC1900-800	22.6	7	800	950	1220
MRC1900-850	24.2	8	850	850	1100
MRC1900-900	25.6	8	900	800	1030
MRC1900-950	27.2	9	950	750	970
MRC1900-1000	28.6	9	1000	700	910

#### Note

- ※1. Maximum loading weight per pre-roller.  
 at Roller A : When load extends to Roller A.  
 at Point B : When load extends to distance L/4 from stopper.

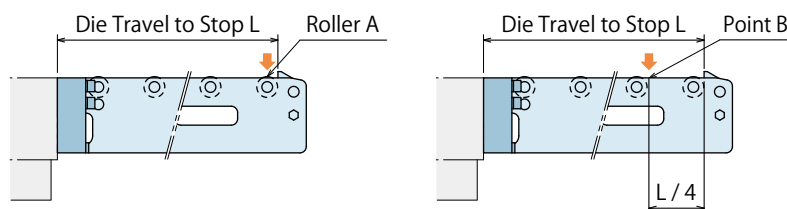
Clamp  
Hydraulic Unit  
Operation Control PanelDie Lifter  
Pre-Roller

Accessories

Cautions  
Company Profile

Die Lifter

RA

RB

Pre-Roller

MRC

MRD

MRE/MRF

MRG

MRJ/MRK

External Dimensions : Removable Pre-Roller (MRC0750-□)

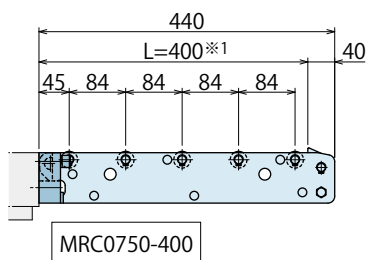
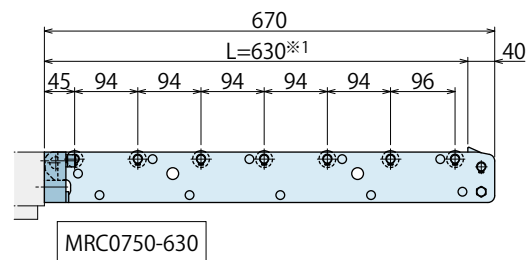
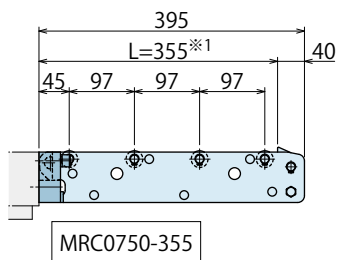
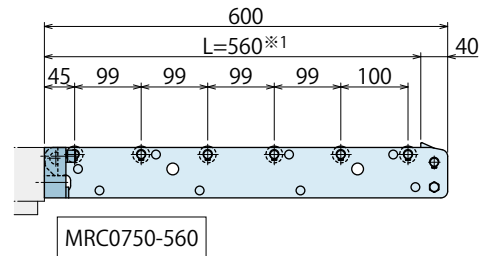
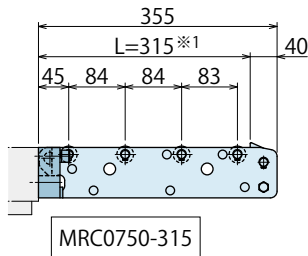
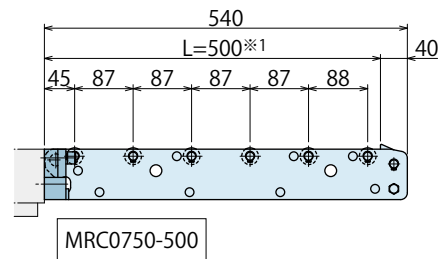
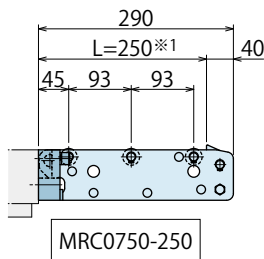
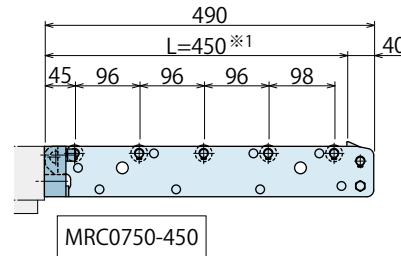
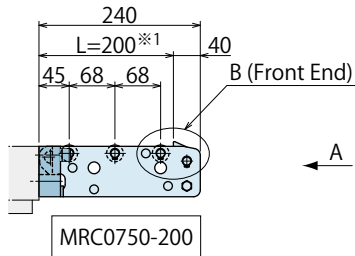
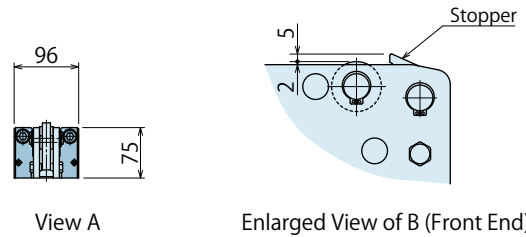
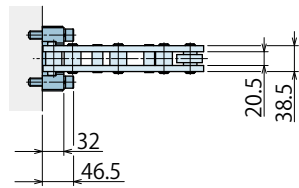

Note

※1. Indicates the die travel L.

External Dimensions : Mounting Block (MRC0750-B)

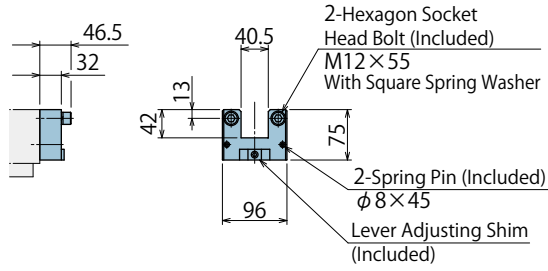

Machining Dimension of Block Mounting Area

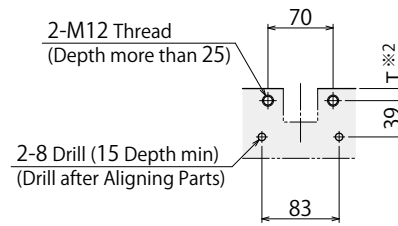

RA Die Lifter		(mm)
Model	Lift-Up Stroke	Dimension T <sup>※2</sup>
RA018	1.5	13.5
RA022		
RA028	2	13
RA050		

Note

※2. Dimension T should be processed according to RA die lifter which is used with the block.

External Dimensions : Removable Pre-Roller (MRC1190-□)

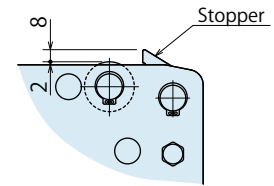
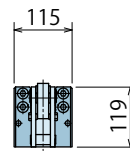
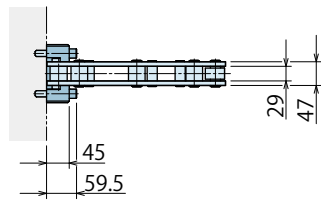

View A

Enlarged View of B (Front End)

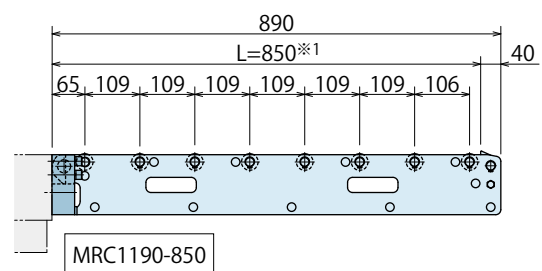
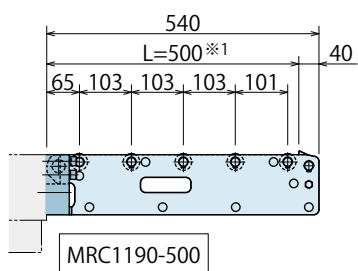
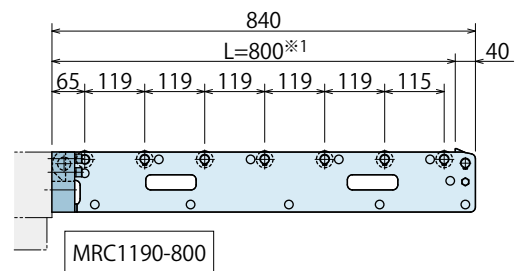
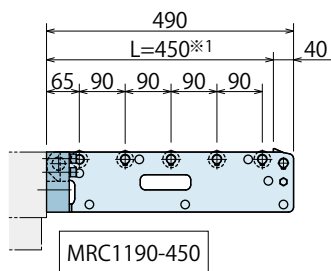
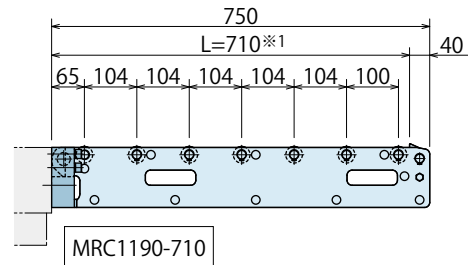
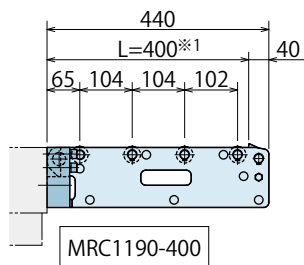
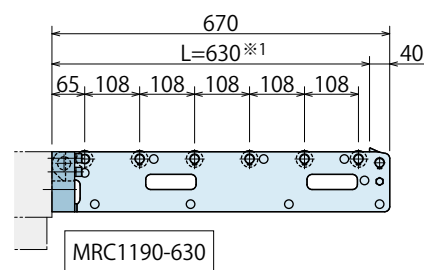
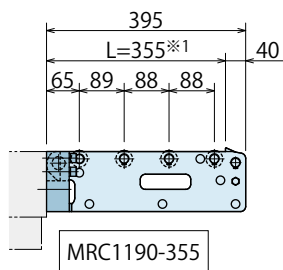
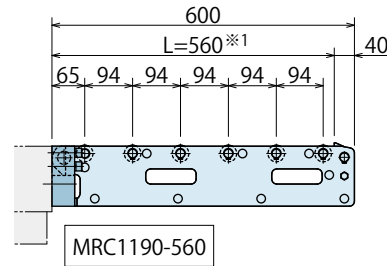
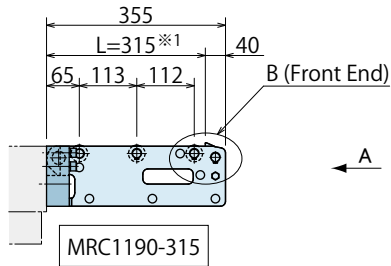

Note

※1. Indicates the die travel L.

External Dimensions : Mounting Block (MRC1190-B) Machining Dimension of Block Mounting Area

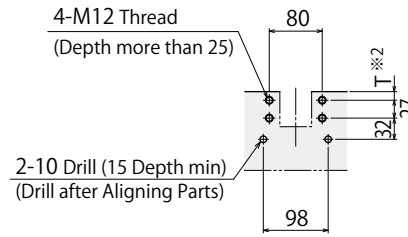
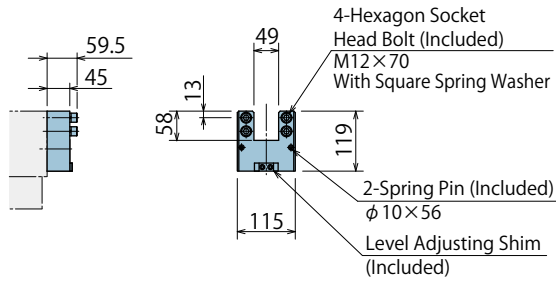

(mm)

RA Die Lifter		Dimension T※2
Model	Lift-Up Stroke	
RA018	1.5	13.5
RA022		
RA028	2	13
RA050		

Note

※2. Dimension T should be processed according to RA die lifter which is used with the block.

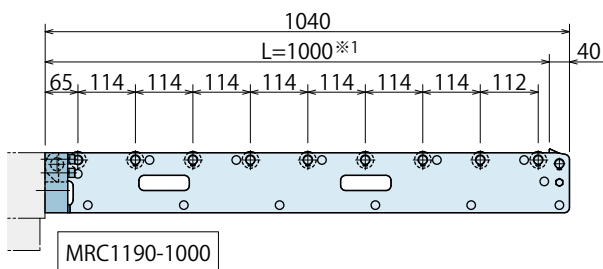
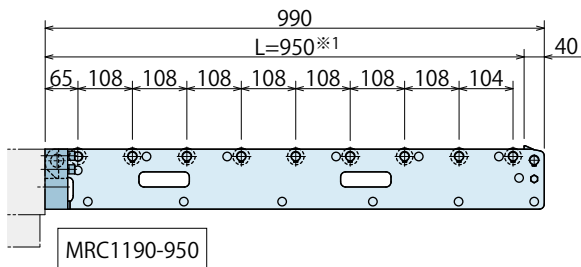
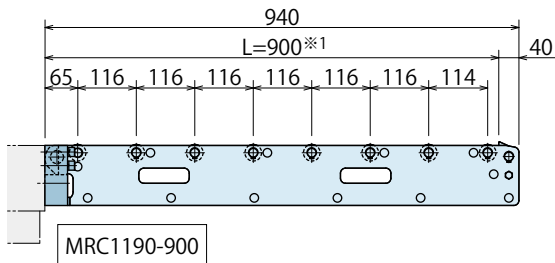



External Dimensions : Removable Pre-Roller (MRC1500-□)

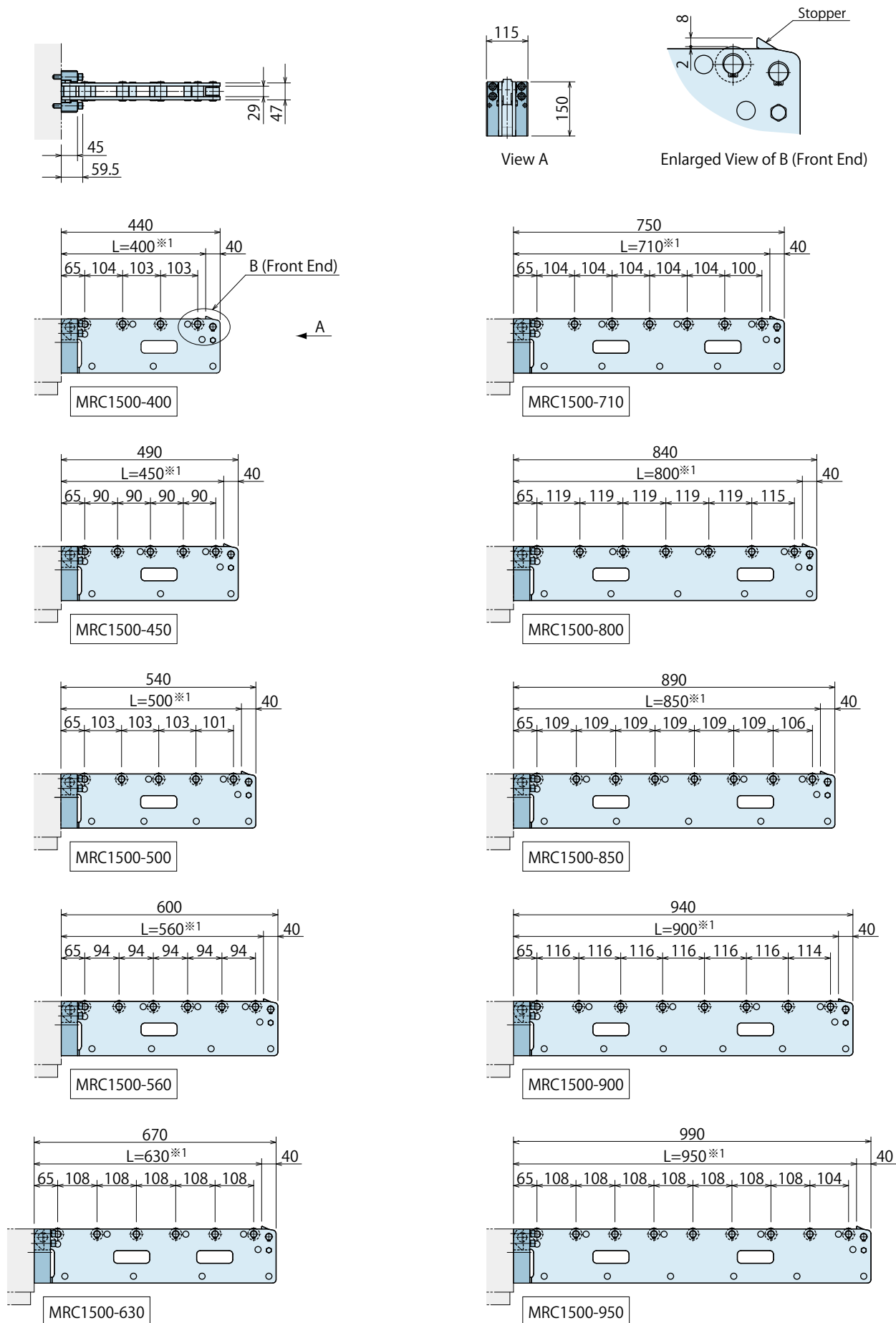

Note  
 ※1. Indicates the die travel L.

External Dimensions : Mounting Block (MRC1500-B) Machining Dimension of Block Mounting Area

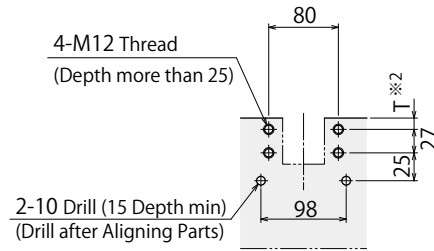
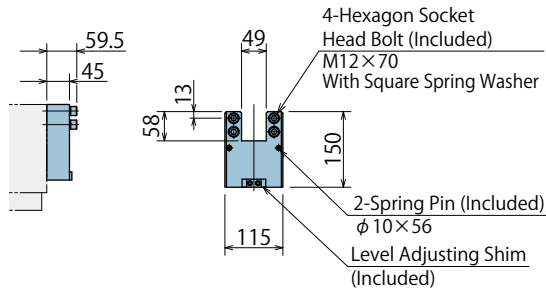

(mm)

RA Die Lifter		Dimension T <sup>※2</sup>
Model	Lift-Up Stroke	
RA018	1.5	13.5
RA022		
RA028	2	13
RA050		

Note

※2. Dimension T should be processed according to RA die lifter which is used with the block.

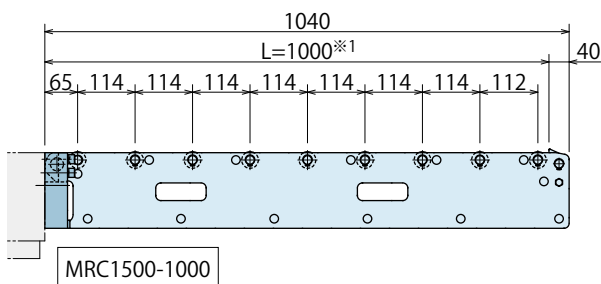

External Dimensions : Removable Pre-Roller (MRC1900-□)

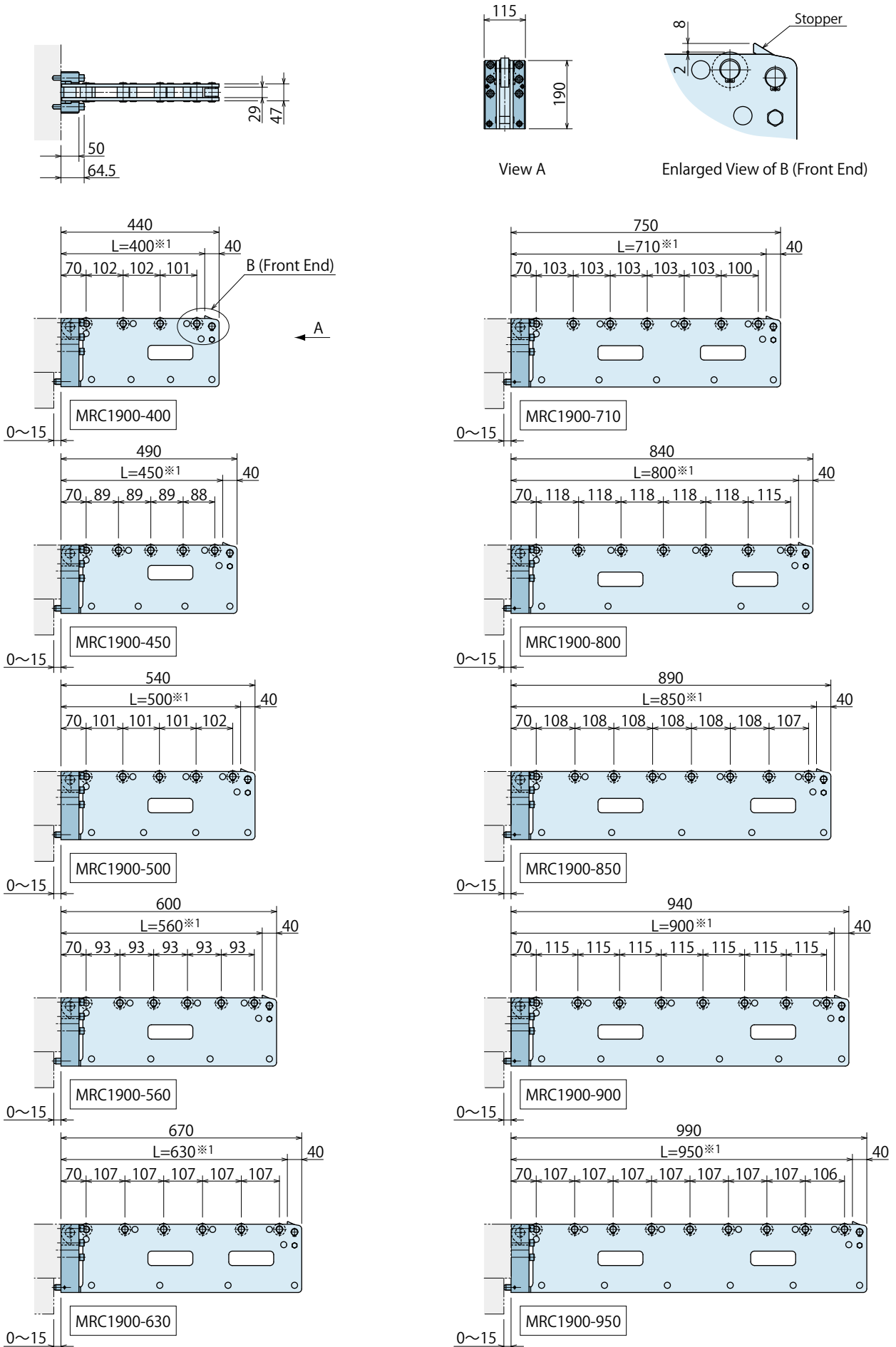

Note  
 ※1. Indicates the die travel L.

External Dimensions : Mounting Block (MRC1900-B) Machining Dimension of Block Mounting Area

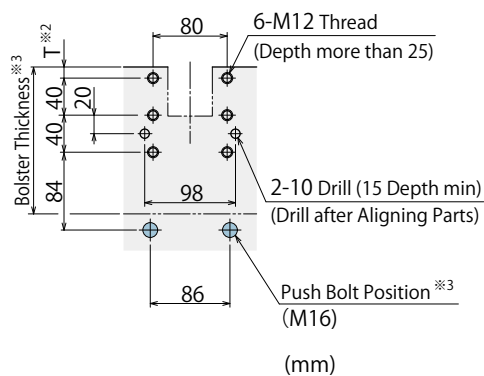
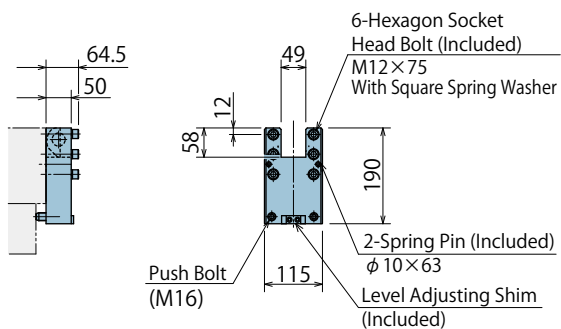

RA Die Lifter		Dimension T ※2
Model	Lift-Up Stroke	
RA018	1.5	12.5
RA022		
RA028	2	12
RA050		

Notes

- ※2. Dimension T should be processed according to RA die lifter which is used with the block.
- ※3. Use a push bolt when the bolster thickness is 160mm or less.

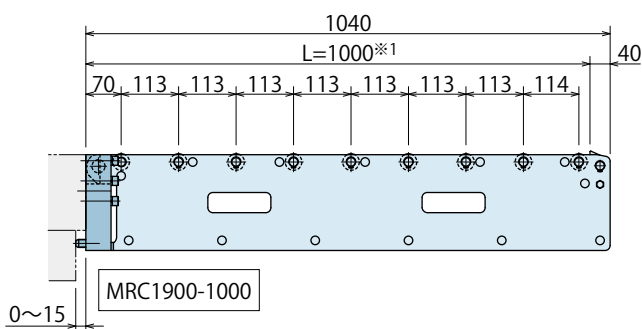

Clamp  
Hydraulic Unit  
Operation Control Panel

Die Lifter  
Pre-Roller

Accessories

Cautions  
Company Profile

Die Lifter

RA

RB

Pre-Roller

MRC

MRD

MRE/MRF

MRG

MRJ/MRK

Model No. Indication

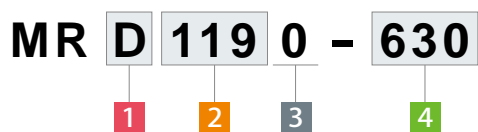

1 Frame Storage Type

- C : Removable Type ————— P.093
- D : Removable•Vertical Folding Type ————— P.103
- E : Horizontal Folding Type (Inside Arm) ————— P.113
- F : Horizontal Folding Type (Outside Arm) ————— P.113
- G : Removable Type (With Stand) ————— P.121
- J : Horizontal Folding Type (With Stand) (Inside Arm) ————— P.129
- K : Horizontal Folding Type (With Stand) (Outside Arm) ————— P.129



2 Mounting Block Height (Pre-Roller Height)

- 075 : Mounting Block Height 75 mm
- 119 : Mounting Block Height 119 mm
- 150 : Mounting Block Height 150 mm
- 190 : Mounting Block Height 190 mm

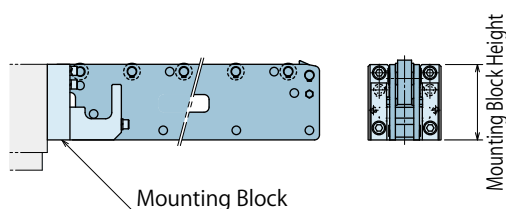

3 Design No.

- 0 : Revision Number

4 Die Travel L • Mounting Block Type

**Dimensions** : Die Travel L (Distance that the die can be pulled out)  
(Please refer to the specifications)

- B : Mounting Block

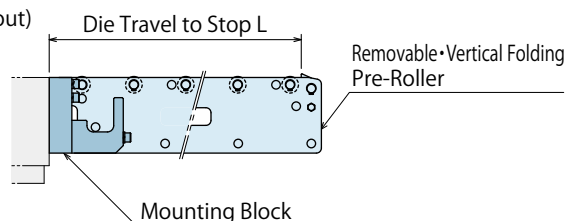

Compatible Mounting Blocks

Pre-Roller Model No.	Mounting Block Model No.	Mounting Block Weight (kg)
MRD0750-□	MRD0750-B	1.7
MRD1190-□	MRD1190-B	5.0
MRD1500-□	MRD1500-B	6.0
MRD1900-□	MRD1900-B	8.3

Note

1. MRD Pre-Roller and MRD-B Mounting Block are sold separately.  
Order by type and number required.

## Specifications

### MRD0750-□

Model No.	Weight (kg)	Number of Rollers	Die Travel to Stop L (mm)	Max. Loading Weight each (kg) <sup>※1</sup>	
				at Roller A	at Point B
MRD0750-200	3.0	3	200	850	1020
MRD0750-250	3.5	3	250	650	800
MRD0750-315	4.3	4	315	500	620
MRD0750-355	4.8	4	355	450	560
MRD0750-400	5.3	5	400	400	500
MRD0750-450	5.8	5	450	350	440
MRD0750-500	6.4	6	500	300	380
MRD0750-560	7.1	6	560	270	340
MRD0750-630	8.0	7	630	240	310

### MRD1190-□

Model No.	Weight (kg)	Number of Rollers	Die Travel to Stop L (mm)	Max. Loading Weight each (kg) <sup>※1</sup>	
				at Roller A	at Point B
MRD1190-315	6.7	3	315	1500	1840
MRD1190-355	7.6	4	355	1300	1610
MRD1190-400	8.4	4	400	1100	1370
MRD1190-450	9.4	5	450	950	1190
MRD1190-500	10.3	5	500	800	1010
MRD1190-560	11.3	6	560	700	890
MRD1190-630	12.4	6	630	650	830
MRD1190-710	14.0	7	710	500	640
MRD1190-800	15.5	7	800	450	580
MRD1190-850	16.5	8	850	400	510
MRD1190-900	17.5	8	900	350	450
MRD1190-950	18.6	9	950	300	380
MRD1190-1000	19.5	9	1000	250	320

### MRD1500-□

Model No.	Weight (kg)	Number of Rollers	Die Travel to Stop L (mm)	Max. Loading Weight each (kg) <sup>※1</sup>	
				at Roller A	at Point B
MRD1500-400	9.9	4	400	1500	1870
MRD1500-450	11.2	5	450	1350	1700
MRD1500-500	12.3	5	500	1200	1520
MRD1500-560	13.4	6	560	1050	1330
MRD1500-630	14.8	6	630	900	1150
MRD1500-710	16.8	7	710	800	1020
MRD1500-800	18.7	7	800	700	900
MRD1500-850	20.0	8	850	600	770
MRD1500-900	21.1	8	900	550	710
MRD1500-950	22.4	9	950	500	640
MRD1500-1000	23.5	9	1000	450	580

### MRD1900-□

Model No.	Weight (kg)	Number of Rollers	Die Travel to Stop L (mm)	Max. Loading Weight each (kg) <sup>※1</sup>	
				at Roller A	at Point B
MRD1900-400	11.9	4	400	2000	2500
MRD1900-450	13.4	5	450	1800	2260
MRD1900-500	14.8	5	500	1600	2020
MRD1900-560	15.9	6	560	1400	1780
MRD1900-630	17.8	6	630	1250	1600
MRD1900-710	20.2	7	710	1100	1410
MRD1900-800	22.6	7	800	950	1220
MRD1900-850	24.2	8	850	850	1100
MRD1900-900	25.6	8	900	800	1030
MRD1900-950	27.2	9	950	750	970
MRD1900-1000	28.6	9	1000	700	910

#### Note

- ※1. Maximum loading weight per pre-roller.  
 at Roller A : When load extends to Roller A.  
 at Point B : When load extends to distance L/4 from stopper.

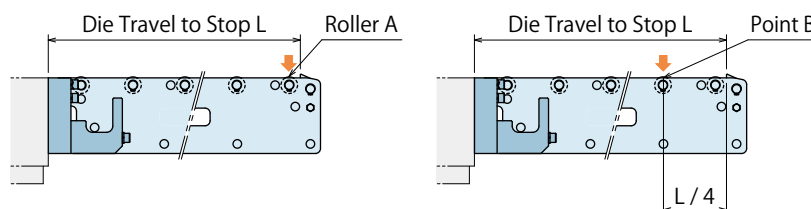
Clamp  
Hydraulic Unit  
Operation Control PanelDie Lifter  
Pre-Roller

Accessories

Cautions  
Company Profile

Die Lifter

RA

RB

Pre-Roller

MRC

MRD

MRE/MRF

MRG

MRJ/MRK

External Dimensions : Removable • Vertical Folding Pre-Roller (MRD0750-□)

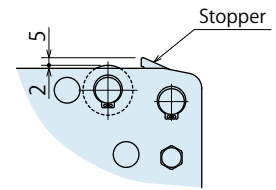
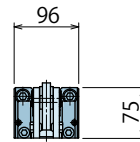
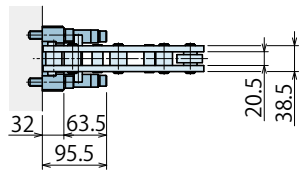

View A

Enlarged View of B (Front End)

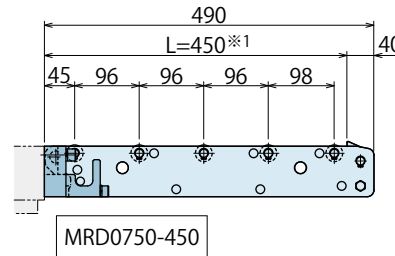
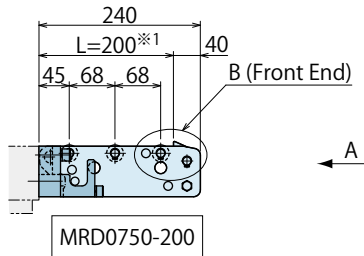

MRD0750-200

MRD0750-450

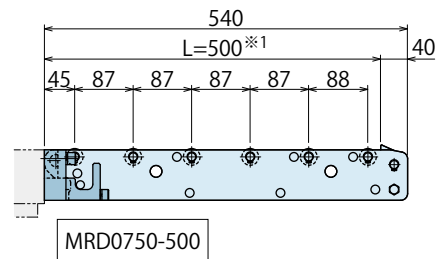
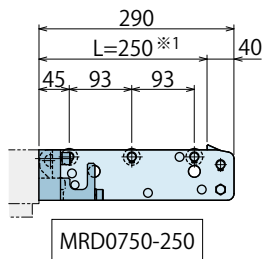

MRD0750-250

MRD0750-500

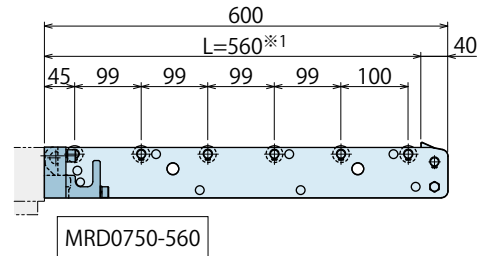
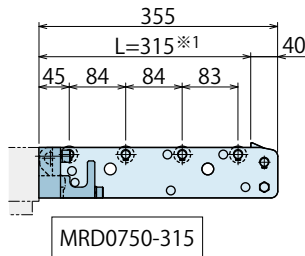

MRD0750-315

MRD0750-560

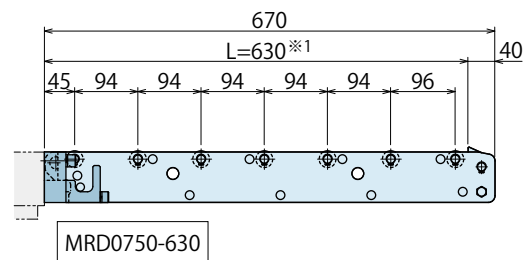
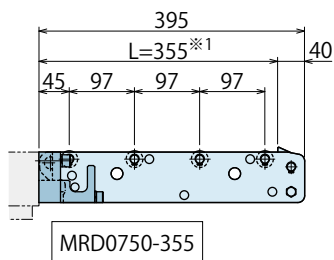

MRD0750-355

MRD0750-630

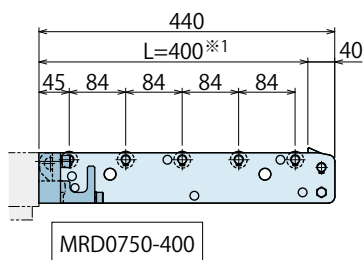

MRD0750-400

Note

※1. Indicates the die travel L.

External Dimensions : Mounting Block (MRD0750-B) Machining Dimension of Block Mounting Area

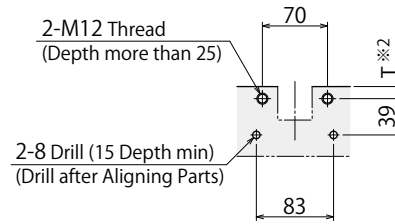
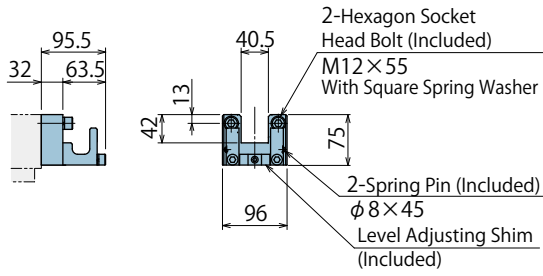

Dimension when Folded

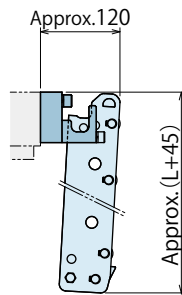

(mm)

RA Die Lifter		Dimension T※2
Model	Lift-Up Stroke	
RA018	1.5	13.5
RA022		
RA028	2	13
RA050		

Note

※2. Dimension T should be processed according to RA Die Lifter which is used with the block.

Clamp  
Hydraulic Unit  
Operation Control Panel

Die Lifter  
Pre-Roller

Accessories

Cautions  
Company Profile

Die Lifter

RA

RB

Pre-Roller

MRC

**MRD**

MRE/MRF

MRG

MRJ/MRK



External Dimensions : Removable • Vertical Folding Pre-Roller (MRD1190-□)

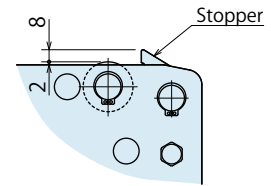
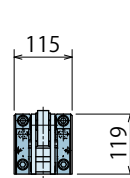
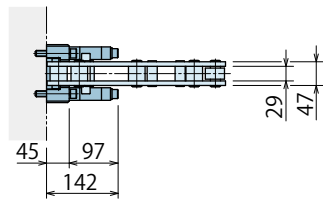

View A

Enlarged View of B (Front End)

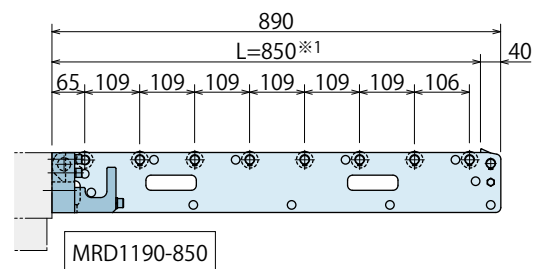
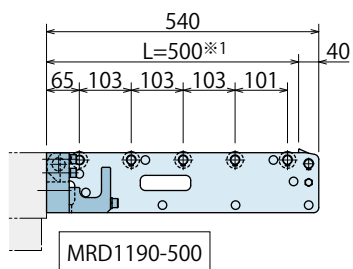
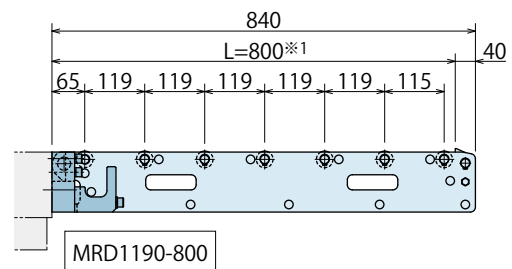
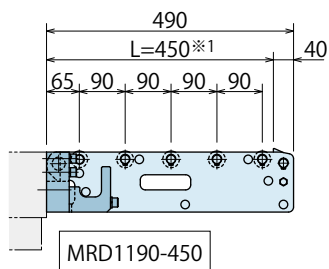
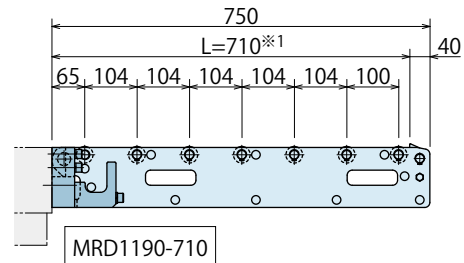
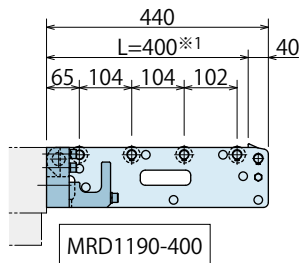
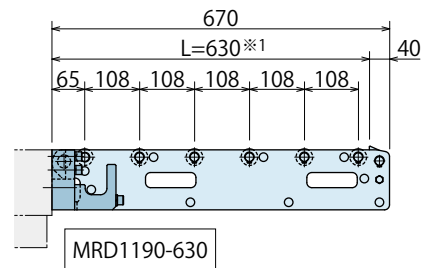
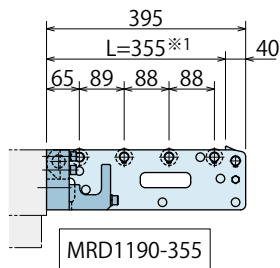
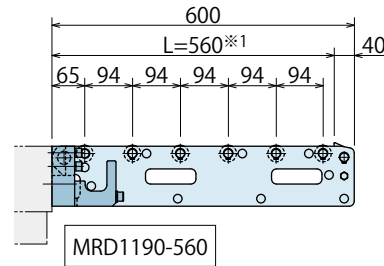
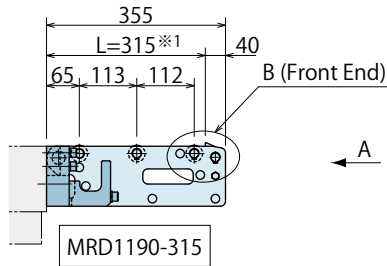

Note

※1. Indicates the die travel L.

External Dimensions : Mounting Block (MRD1190-B) Machining Dimension of Block Mounting Area

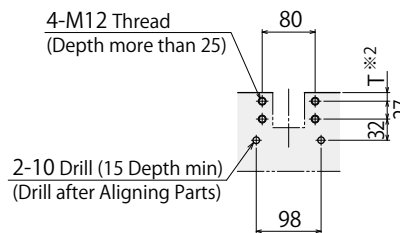
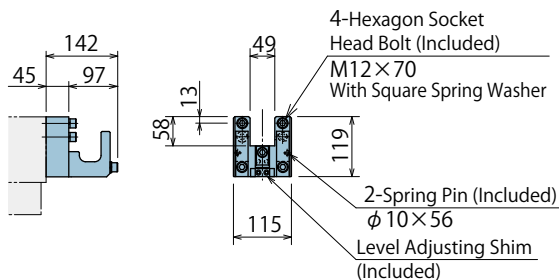

Dimension when Folded

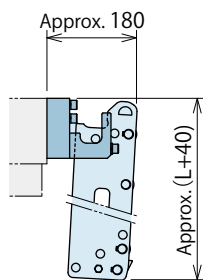

(mm)

RA Die Lifter		Dimension T※2
Model	Lift-Up Stroke	
RA018	1.5	13.5
RA022		
RA028	2	13
RA050		

Note

※2. Dimension T should be processed according to RA Die Lifter which is used with the block.

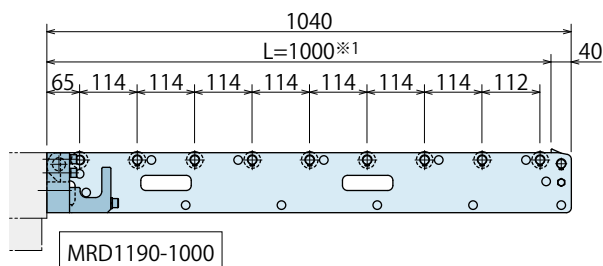
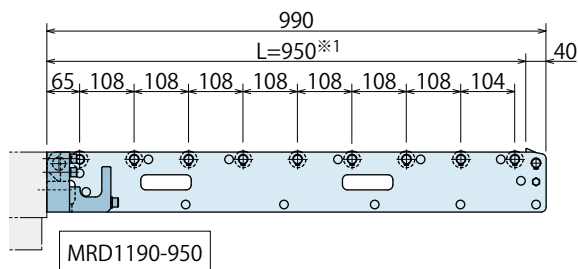
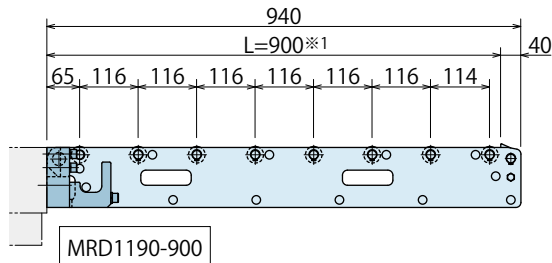

External Dimensions : Removable • Vertical Folding Pre-Roller (MRD1500-□)

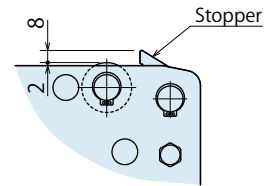
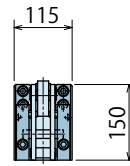
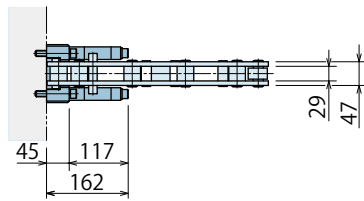

View A

Enlarged View of B (Front End)

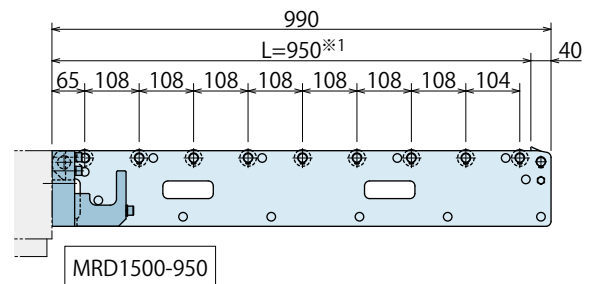
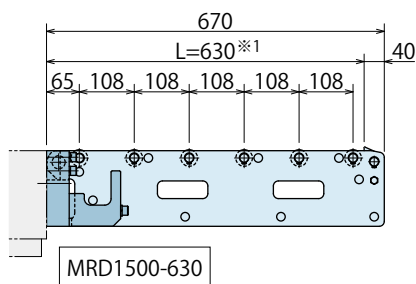
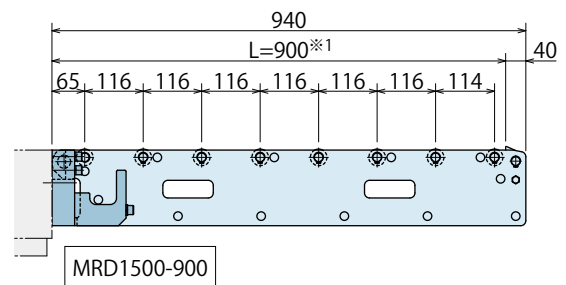
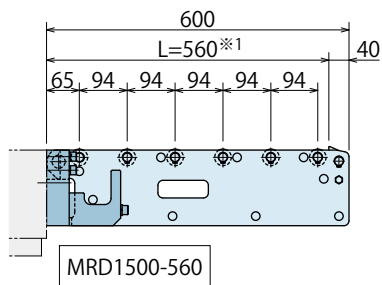
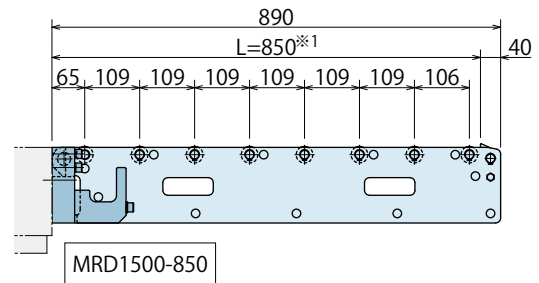
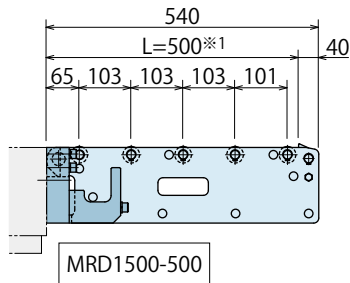
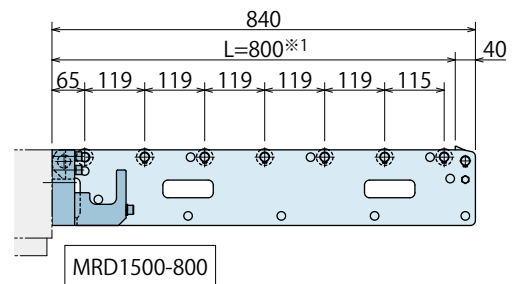
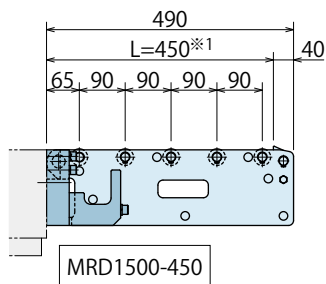
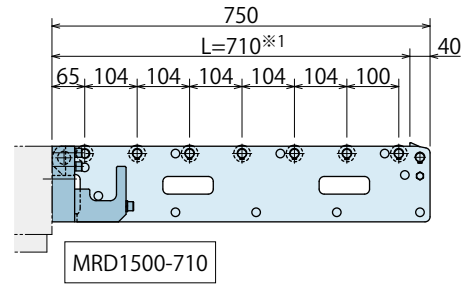
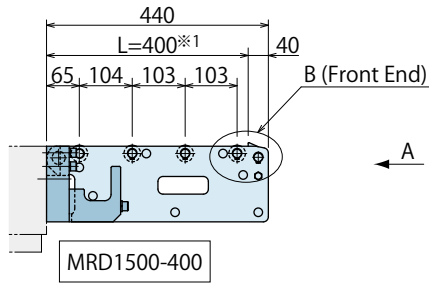

Note

※1. Indicates the die travel L.

External Dimensions : Mounting Block (MRD1500-B) Machining Dimension of Block Mounting Area

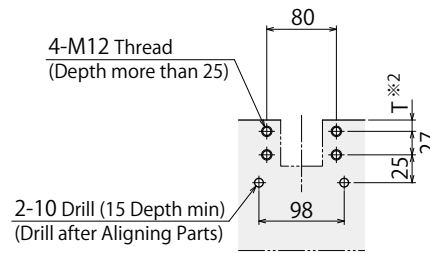
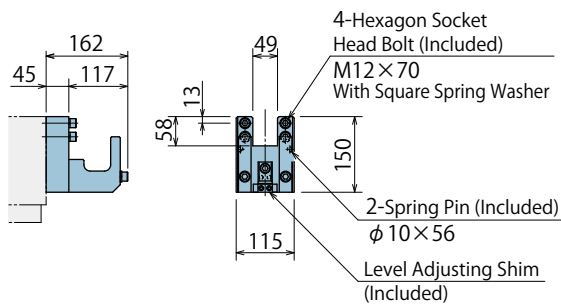

Dimension when Folded

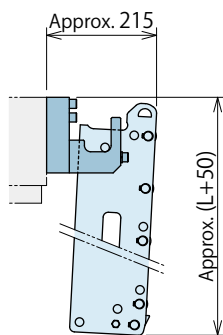

(mm)

RA Die Lifter		Dimension T <sup>※2</sup>
Model	Lift-Up Stroke	
RA018	1.5	13.5
RA022		
RA028	2	13
RA050		

Note

※2. Dimension T should be processed according to RA Die Lifter which is used with the block.

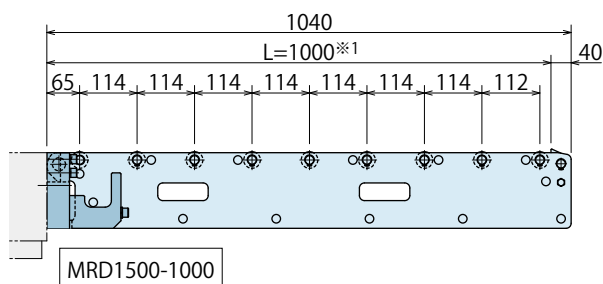

External Dimensions : Removable • Vertical Folding Pre-Roller (MRD1900-□)

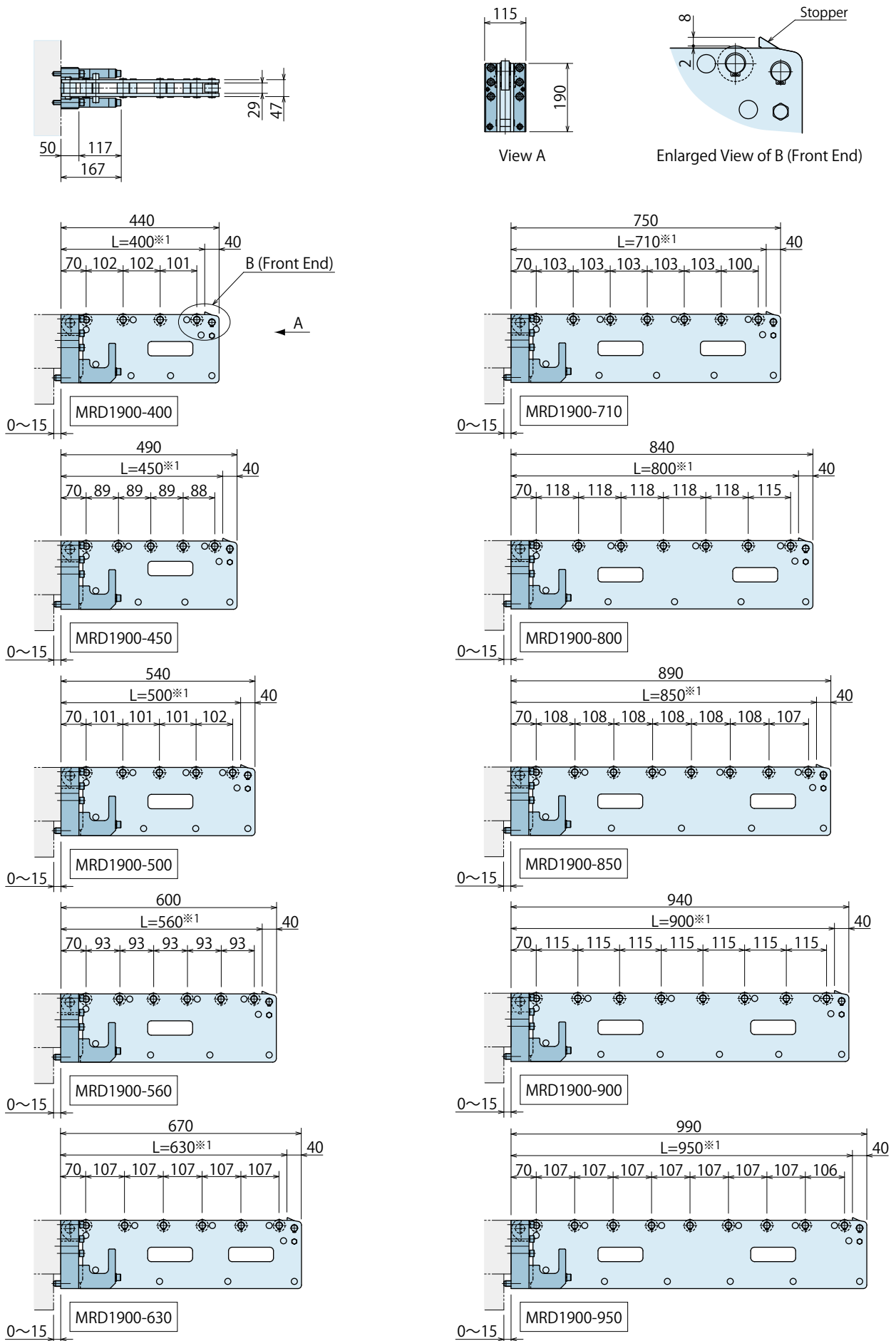

Note  
 ※1. Indicates the die travel L.

External Dimensions : Mounting Block (MRD1900-B) Machining Dimension of Block Mounting Area

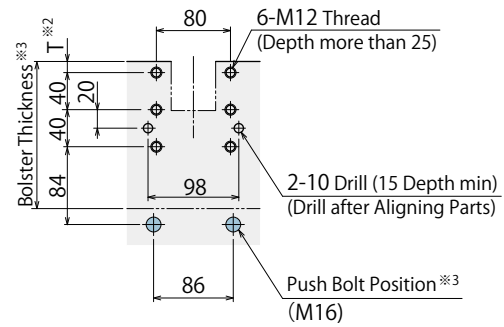
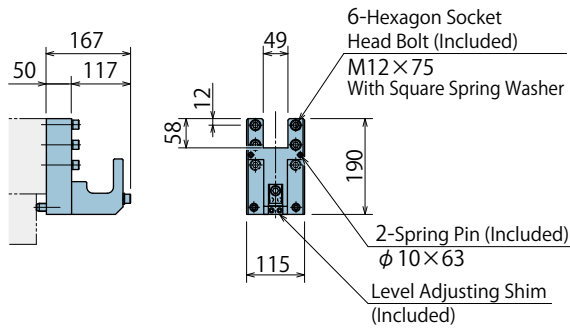

Dimension when Folded

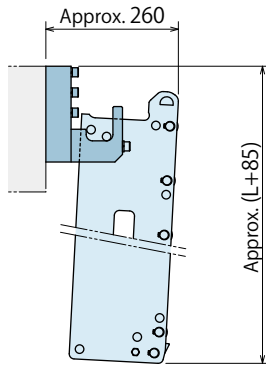

(mm)

RA Die Lifter		Dimension T <sup>※2</sup>
Model	Lift-Up Stroke	
RA018	1.5	12.5
RA022		
RA028	2	12
RA050		

Notes

- ※2. Dimension T should be processed according to RA Die Lifter which is used with the block.
- ※3. Use a push bolt when the bolster thickness is 160mm or less.

Clamp  
Hydraulic Unit  
Operation Control Panel

Die Lifter  
Pre-Roller

Accessories

Cautions  
Company Profile

Die Lifter

RA

RB

Pre-Roller

MRC

**MRD**

MRE/MRF

MRG

MRJ/MRK

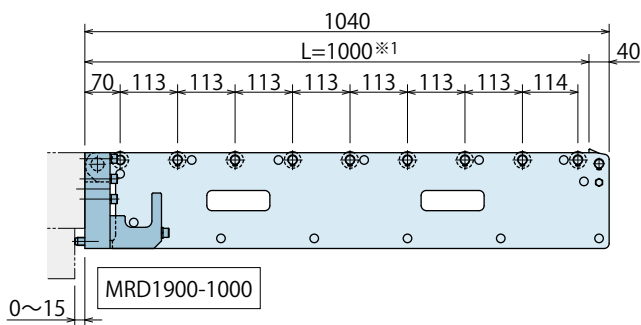

Model No. Indication

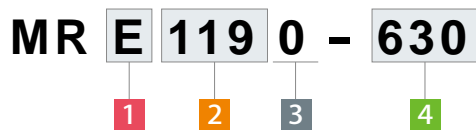

1 Frame Storage Type

- C : Removable Type \_\_\_\_\_ P.093
- D : Removable-Vertical Folding Type \_\_\_\_\_ P.103
- E : Horizontal Folding Type (Inside Arm) \_\_\_\_\_ P.113
- F : Horizontal Folding Type (Outside Arm) \_\_\_\_\_ P.113
- G : Removable Type (With Stand) \_\_\_\_\_ P.121
- J : Horizontal Folding Type (With Stand) (Inside Arm) \_\_\_\_\_ P.129
- K : Horizontal Folding Type (With Stand) (Outside Arm) \_\_\_\_\_ P.129

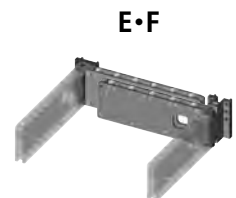

2 Mounting Part Height (Pre-Roller Height)

- 119 : Mounting Part Height 119 mm
- 190 : Mounting Part Height 190 mm
- 295 : Mounting Part Height 295 mm

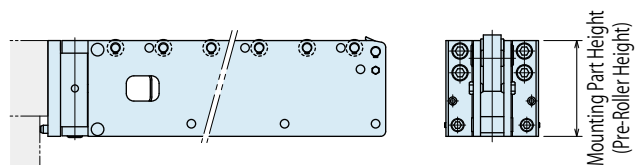

3 Design No.

- 0 : Revision Number

4 Die Travel L

**Dimensions** : Die Travel L  
 (Distance that the die can be pulled out)  
 (Please refer to the specifications)

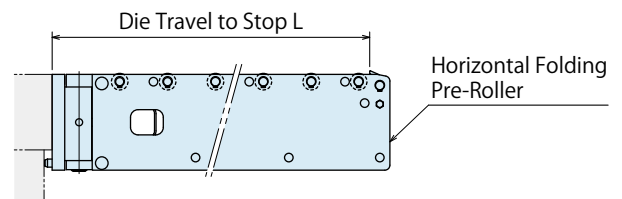

Folding Method

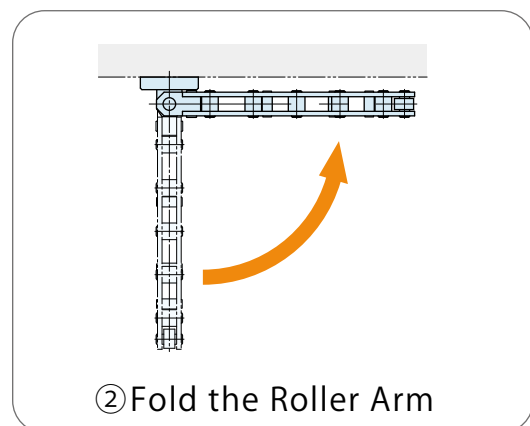
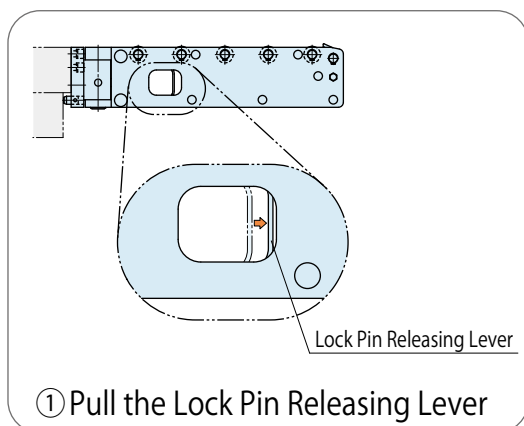

※. Can be folded to the other side as well.

## Specifications

### MRE/MRF1190-□

MRE			MRF			Die Travel to Stop L (mm)	Max. Loading Weight each (kg) <sup>※1</sup>	
Model No.	Weight (kg)	Number of Rollers	Model No.	Weight (kg)	Number of Rollers		at Roller A	at Point B
MRE1190-315	11.3	3	MRF1190-315	12.5	3	315	1500	1840
MRE1190-355	12.1	3	MRF1190-355	13.3	4	355	1400	1730
MRE1190-400	13.0	4	MRF1190-400	14.1	4	400	1200	1500
MRE1190-450	13.8	4	MRF1190-450	15.2	5	450	1000	1250
MRE1190-500	14.9	5	MRF1190-500	16.1	5	500	850	1070
MRE1190-560	15.5	5	MRF1190-560	16.9	6	560	750	950
MRE1190-630	17.0	6	MRF1190-630	18.1	6	630	650	830
MRE1190-710	18.3	6	MRF1190-710	19.6	7	710	550	700

### MRE/MRF1900-□

MRE			MRF			Die Travel to Stop L (mm)	Max. Loading Weight each (kg) <sup>※1</sup>	
Model No.	Weight (kg)	Number of Rollers	Model No.	Weight (kg)	Number of Rollers		at Roller A	at Point B
MRE1900-500	23.1	5	MRF1900-500	25.4	5	500	1600	2020
MRE1900-560	24.3	5	MRF1900-560	26.5	6	560	1400	1780
MRE1900-630	26.4	6	MRF1900-630	28.6	6	630	1250	1600
MRE1900-710	28.5	6	MRF1900-710	30.8	7	710	1100	1410
MRE1900-800	31.3	7	MRF1900-800	33.6	8	800	950	1220
MRE1900-850	32.8	8	MRF1900-850	34.9	8	850	850	1100
MRE1900-900	34.1	8	MRF1900-900	36.4	9	900	800	1030
MRE1900-950	35.8	9	MRF1900-950	37.8	9	950	750	970
MRE1900-1000	37.1	9	MRF1900-1000	39.1	9	1000	700	910

### MRE/MRF2950-□

MRE			MRF			Die Travel to Stop L (mm)	Max. Loading Weight each (kg) <sup>※1</sup>	
Model No.	Weight (kg)	Number of Rollers	Model No.	Weight (kg)	Number of Rollers		at Roller A	at Point B
MRE2950-630	34.6	6	MRF2950-630	39.6	6	630	2000	2560
MRE2950-710	36.4	6	MRF2950-710	41.3	7	710	1750	2250
MRE2950-800	38.6	7	MRF2950-800	43.5	8	800	1500	1930
MRE2950-850	40.0	8	MRF2950-850	44.8	8	850	1400	1810
MRE2950-900	41.1	8	MRF2950-900	45.9	9	900	1300	1680
MRE2950-950	42.4	9	MRF2950-950	47.2	9	950	1200	1550
MRE2950-1000	44.4	9	MRF2950-1000	48.3	9	1000	1100	1430

#### Note

- ※1. Maximum loading weight per pre-roller.  
 at Roller A : When load extends to Roller A.  
 at Point B : When load extends to distance L/4 from stopper.

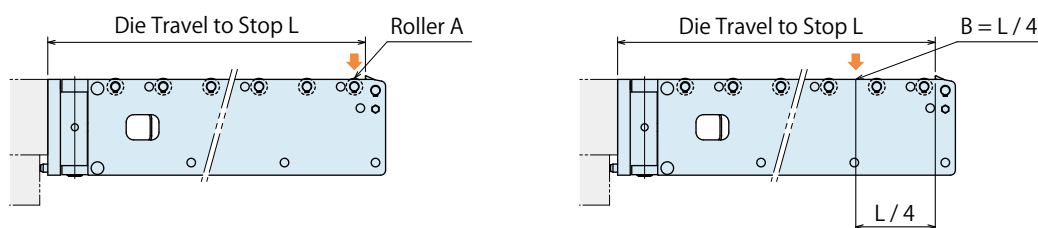



External Dimensions : Horizontal Folding Pre-Roller (MRE/MRF1190-□)

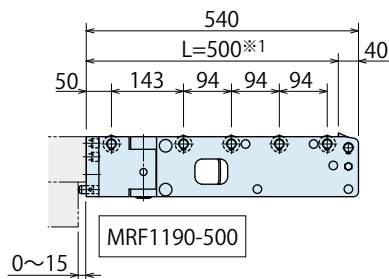
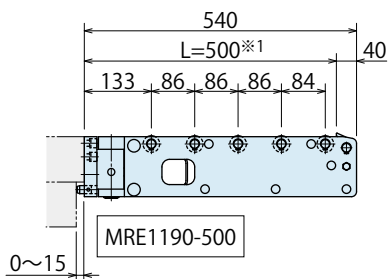
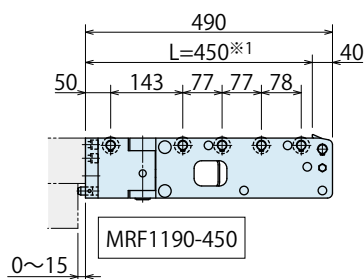
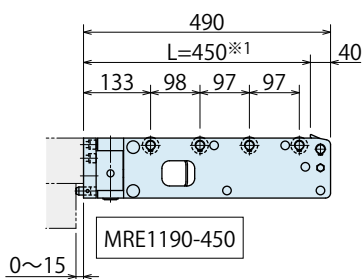
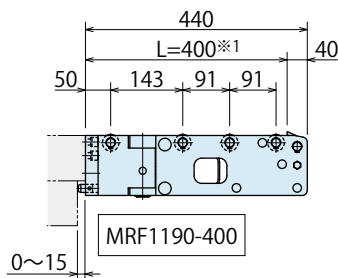
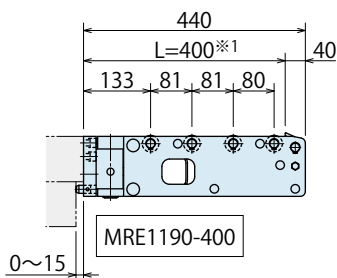
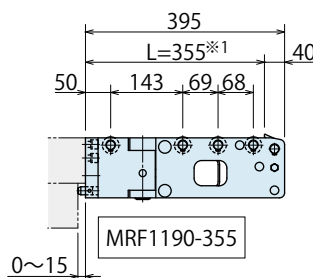
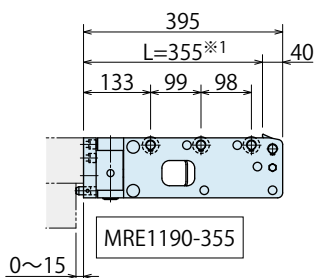
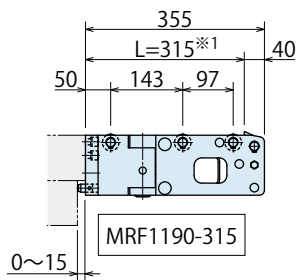
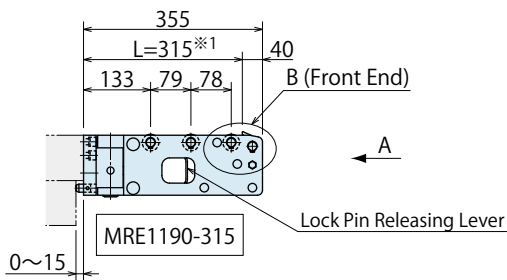
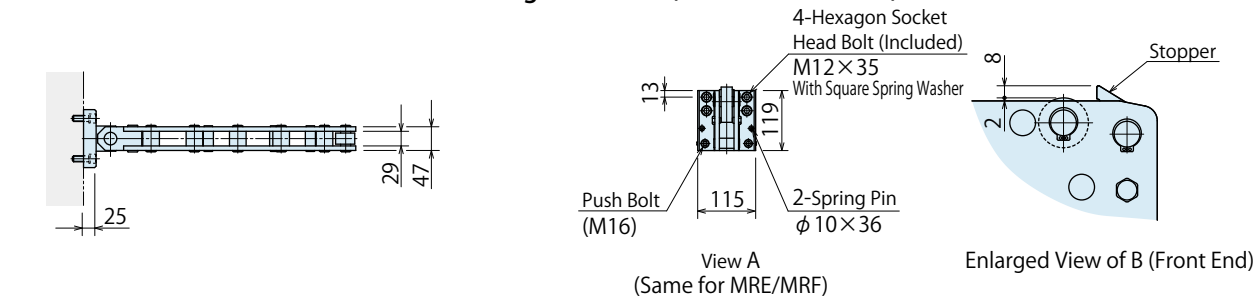

Note  
 ※1. Indicates the die travel L.

### Dimension when Folded

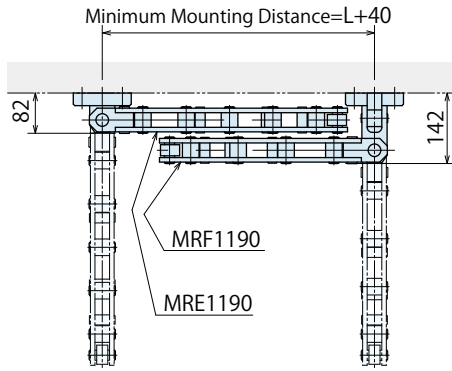

MRE/MRF can swing to both left and right.

### Machining Dimension of Block Mounting Area

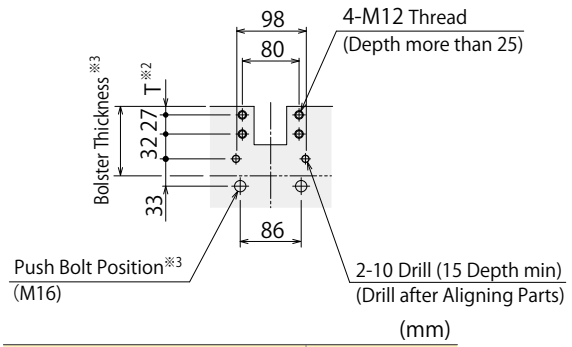

RA Die Lifter		Dimension T <sup>※2</sup>
Model	Lift-Up Stroke	
RA018	1.5	13.5
RA022		
RA028		
RA050	2	13

#### Notes

- ※2. Dimension T should be processed according to RA Die Lifter which is used with the block.
- ※3. Use a push bolt when the bolster thickness is 100mm or less.

#### Die Lifter

RA

RB

#### Pre-Roller

MRC

MRD

**MRE/MRF**

MRG

MRJ/MRK

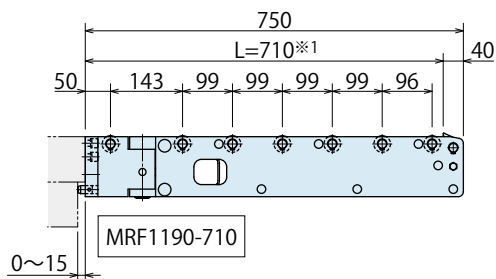
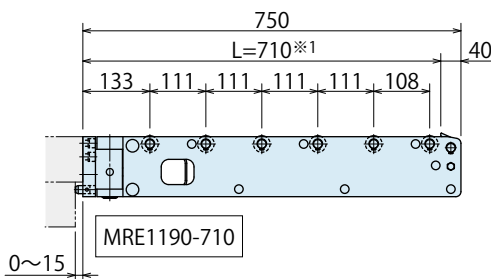
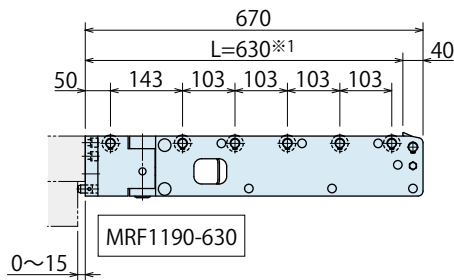
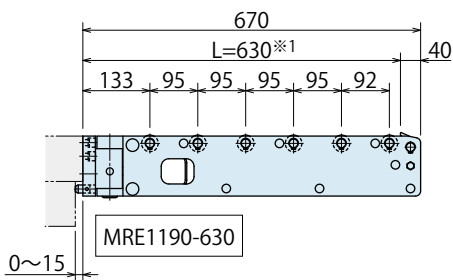
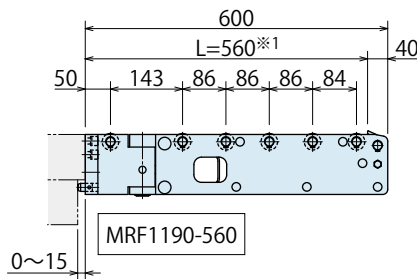
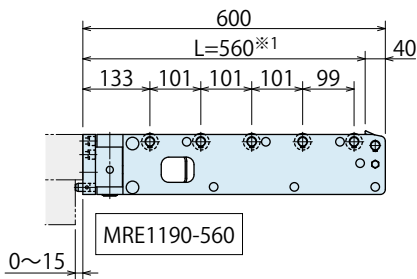

External Dimensions : Horizontal Folding Pre-Roller (MRE/MRF1900-□)

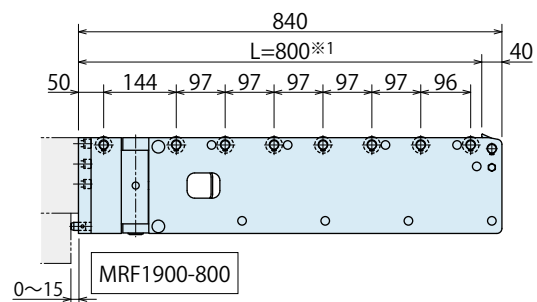
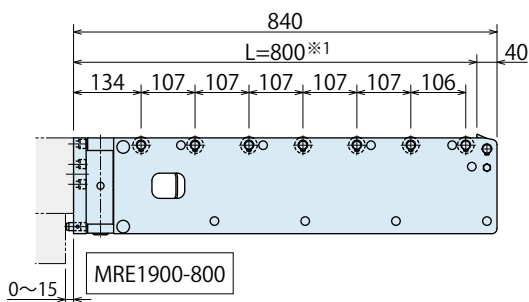
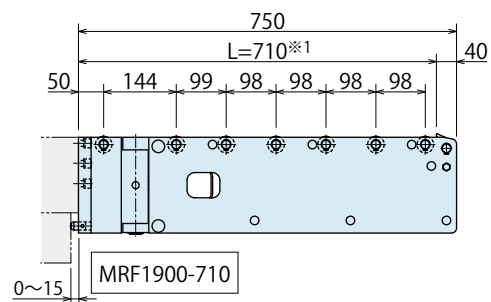
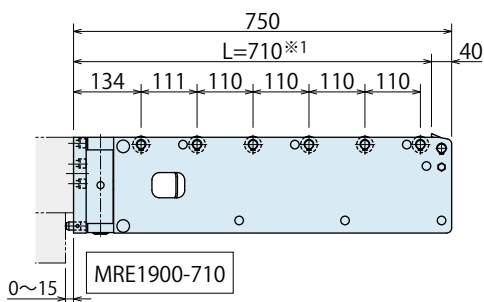
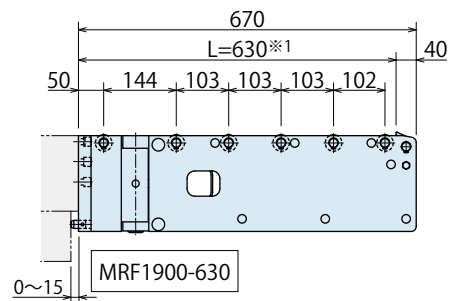
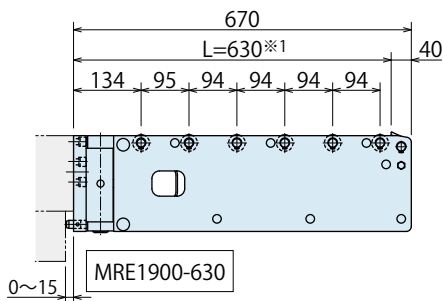
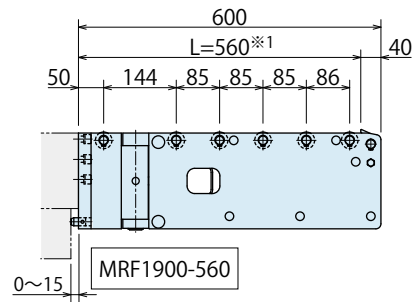
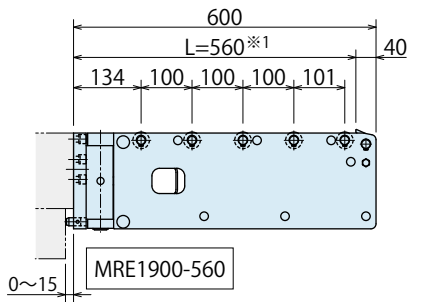
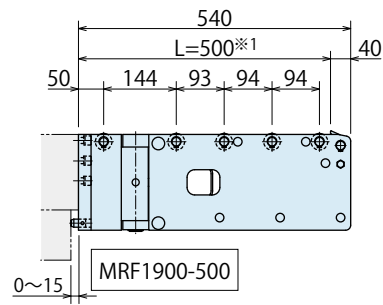
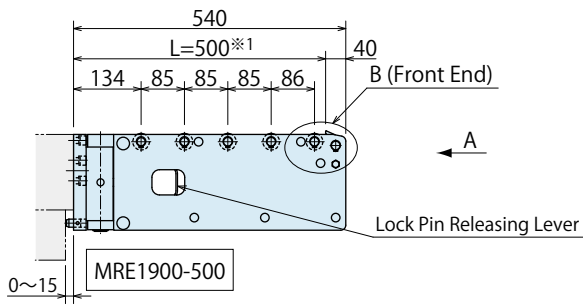
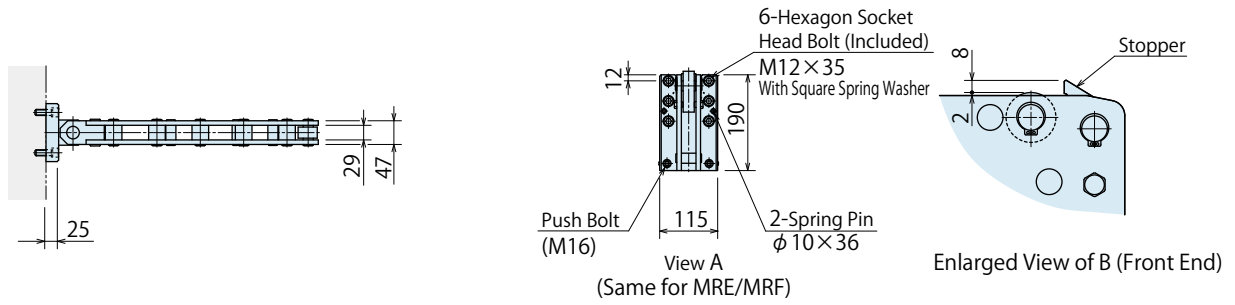

Note  
 ※1. Indicates the die travel L.

Dimension when Folded

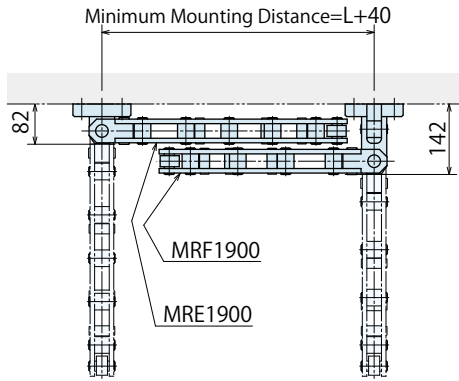

MRE/MRF can swing to both left and right.

Machining Dimension of Block Mounting Area

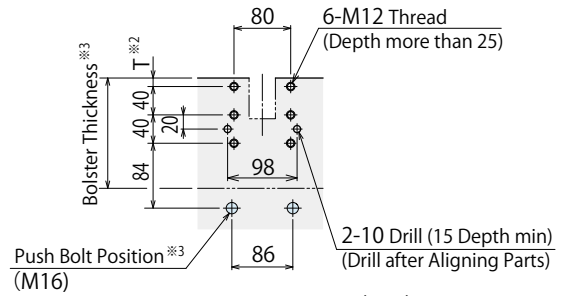

(mm)

RA Die Lifter		Dimension T <sup>※2</sup>
Model	Lift-Up Stroke	
RA018	1.5	12.5
RA022		
RA028	2	12
RA050		

Notes

- ※2. Dimension T should be processed according to RA Die Lifter which is used with the block.
- ※3. Use a push bolt when the bolster thickness is 160mm or less.

Clamp  
Hydraulic Unit  
Operation Control Panel

Die Lifter  
Pre-Roller

Accessories

Cautions  
Company Profile

Die Lifter

RA

RB

Pre-Roller

MRC

MRD

MRE/MRF

MRG

MRJ/MRK

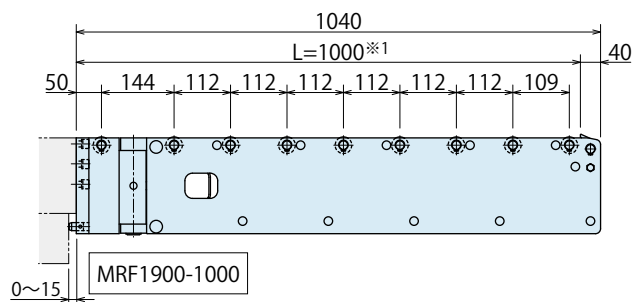
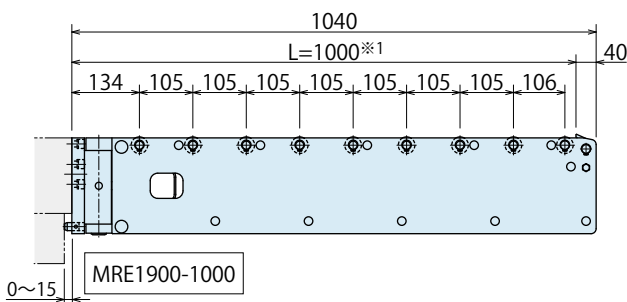
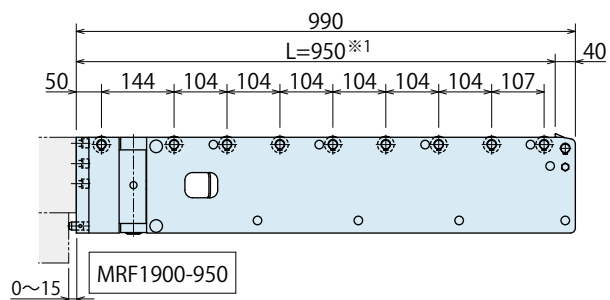
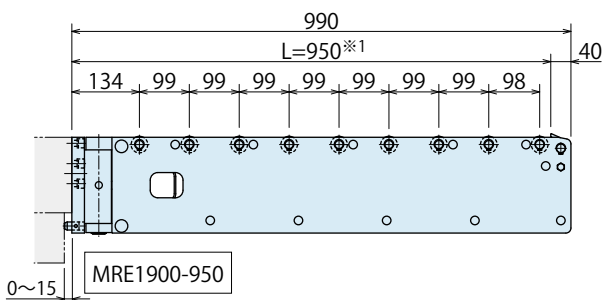
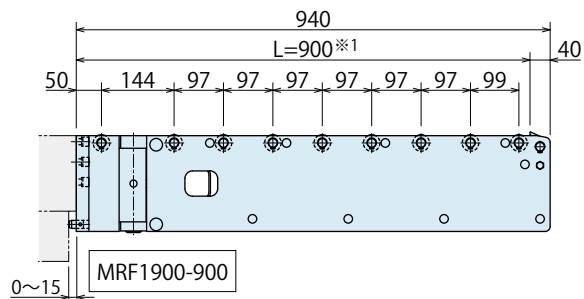
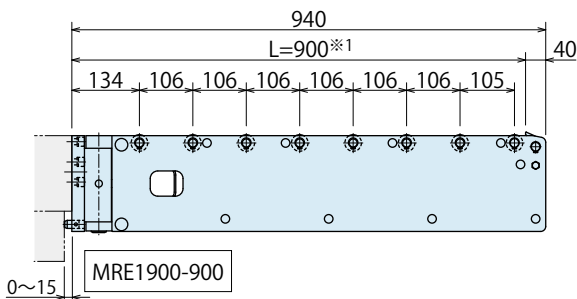
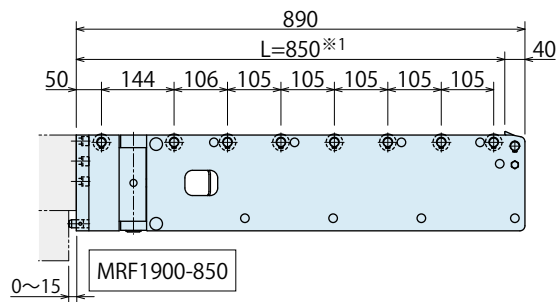
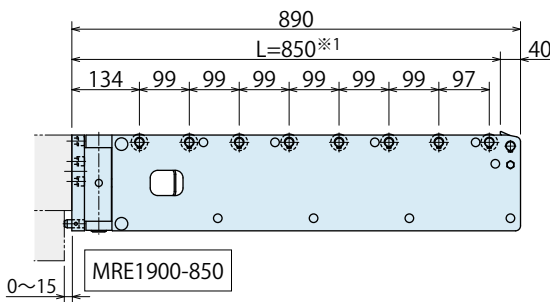

External Dimensions : Horizontal Folding Pre-Roller (MRE/MRF2950-□)

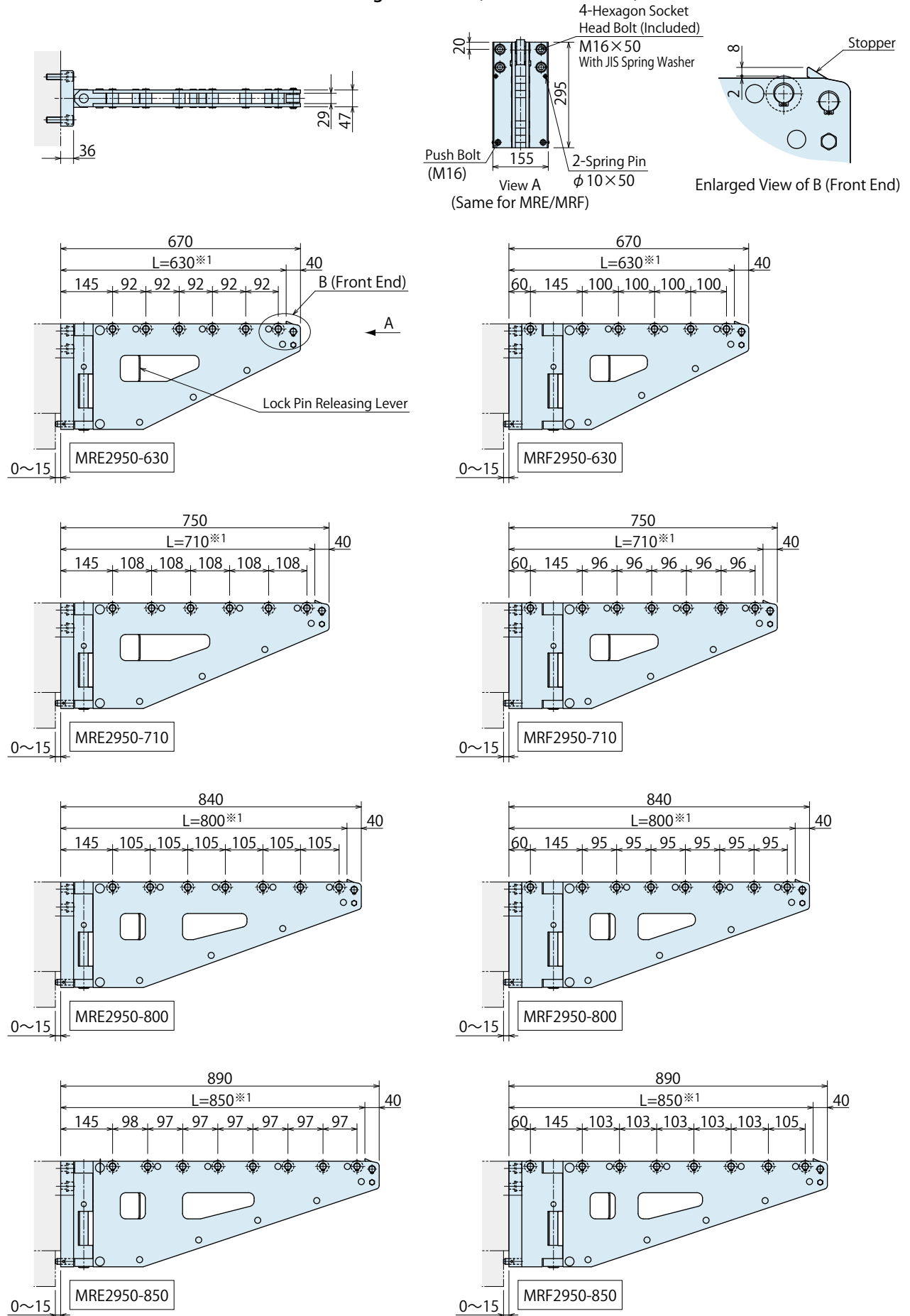

Note

※1. Indicates the die travel L.

● Dimension when Folded

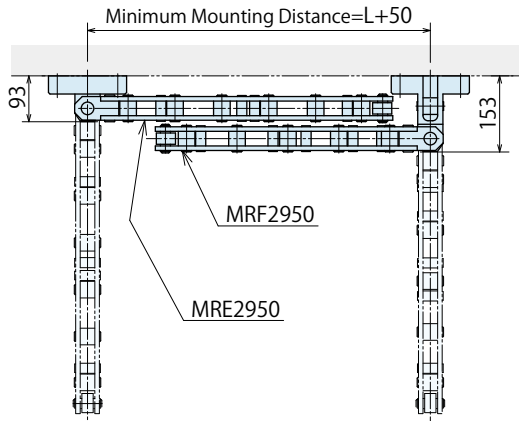

MRE/MRF can swing to both left and right.

● Machining Dimension of Block Mounting Area

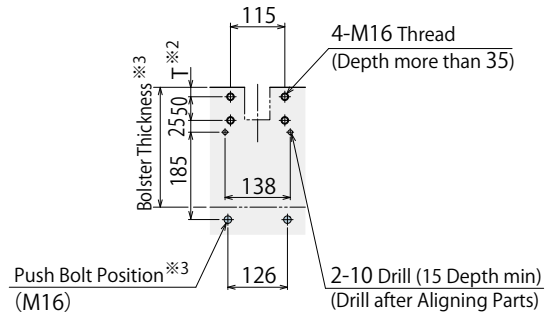

RA Die Lifter		Dimension T <sup>※2</sup>
Model	Lift-Up Stroke	
RA018	1.5	20.5
RA022		
RA028	2	20
RA050		

Notes

- ※2. Dimension T should be processed according to RA Die Lifter which is used with the block.
- ※3. Use a push bolt when the bolster thickness is 245mm or less.

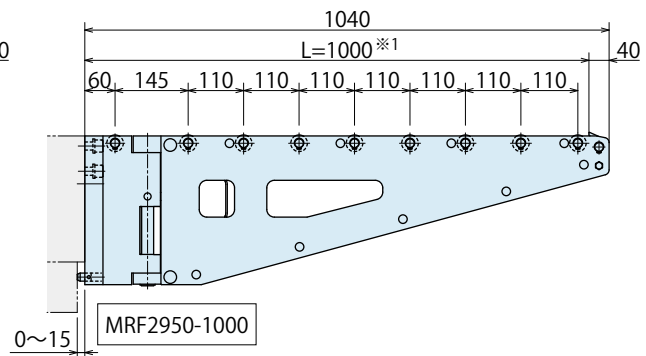
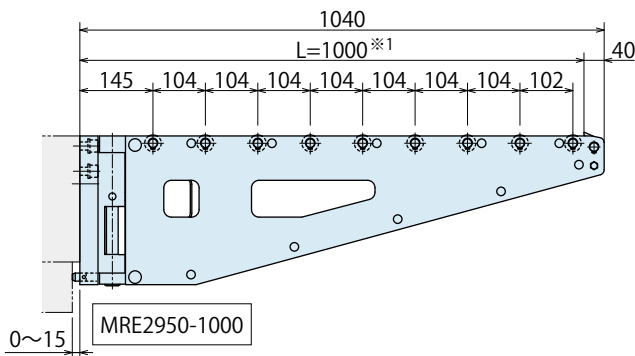
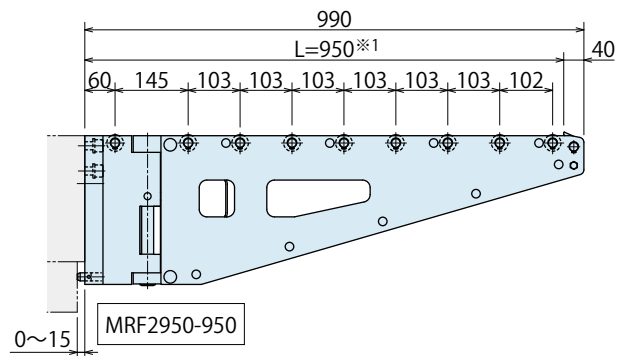
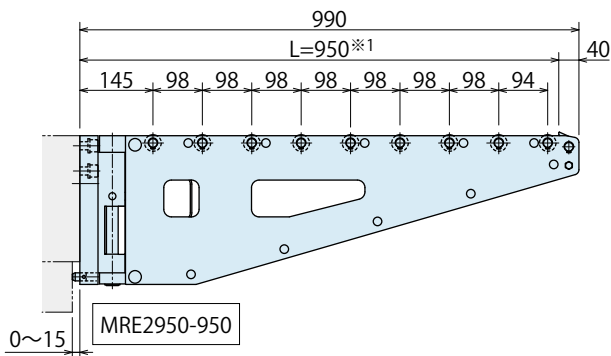
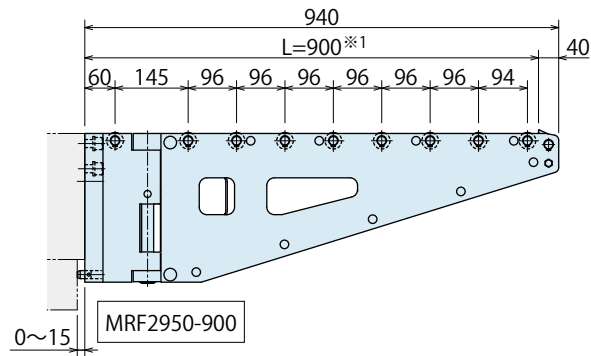
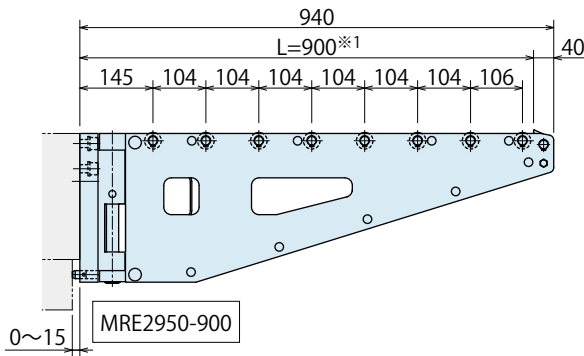

- Clamp
- Hydraulic Unit
- Operation Control Panel
- Die Lifter Pre-Roller**
- Accessories
- Cautions
- Company Profile

Die Lifter

- RA
- RB

Pre-Roller

- MRC
- MRD
- MRE/MRF**
- MRG
- MRJ/MRK

Model No. Indication : Removable Pre-Roller (With Stand)

MR **G** **119** **0** - **710**

1
2
3
4

**1** Frame Storage Type

- C : Removable Type \_\_\_\_\_ P.093
- D : Removable+Vertical Folding Type \_\_\_\_\_ P.103
- E : Horizontal Folding Type (Inside Arm) \_\_\_\_\_ P.113
- F : Horizontal Folding Type (Outside Arm) \_\_\_\_\_ P.113
- G** : Removable Type (With Stand) \_\_\_\_\_ P.121
- J : Horizontal Folding Type (With Stand) (Inside Arm) \_\_\_\_\_ P.129
- K : Horizontal Folding Type (With Stand) (Outside Arm) \_\_\_\_\_ P.129



**2** Mounting Block Height (Pre-Roller Height)

- 119** : Mounting Block Height 119 mm
- 190** : Mounting Block Height 190 mm

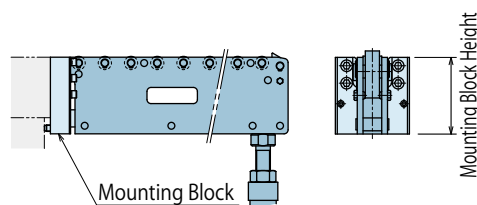

**3** Design No.

- 0** : Revision Number

**4** Die Travel L • Mounting Block Type

**Dimensions** : Die Travel L (Distance that the die can be pulled out)  
 (Please refer to the specifications)

- B** : Mounting Block

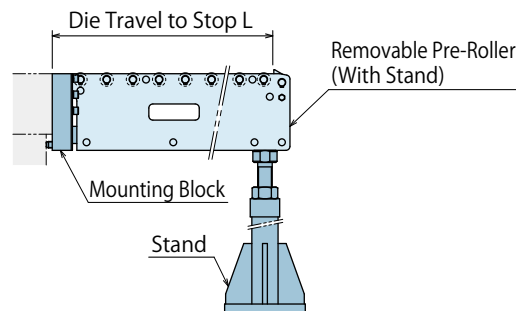

Model No. Indication : Stand

MRH **040** **0** - **A**

1
2

**1** Applicable Bolster Height

- |  |  |
|--|--|
| <ul style="list-style-type: none"> <li>• When using MRG1190-□</li> <li><b>040</b> : 520 ~ 620 mm</li> <li><b>050</b> : 620 ~ 720 mm</li> <li><b>060</b> : 720 ~ 820 mm</li> <li><b>070</b> : 820 ~ 920 mm</li> <li><b>080</b> : 920 ~ 1020 mm</li> <li><b>090</b> : 1020 ~ 1120 mm</li> <li><b>100</b> : 1120 ~ 1220 mm</li> </ul> | <ul style="list-style-type: none"> <li>• When using MRG1900-□</li> <li><b>040</b> : 590 ~ 690 mm</li> <li><b>050</b> : 690 ~ 790 mm</li> <li><b>060</b> : 790 ~ 890 mm</li> <li><b>070</b> : 890 ~ 990 mm</li> <li><b>080</b> : 990 ~ 1090 mm</li> <li><b>090</b> : 1090 ~ 1190 mm</li> <li><b>100</b> : 1190 ~ 1290 mm</li> </ul> |
|--|--|

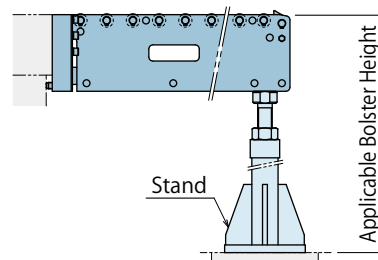

**2** Design No.

- 0** : Revision Number

## Compatible Mounting Blocks

Pre-Roller Model No.	Mounting Block Model	Mounting Block Weight (kg)
MRG1190-□	MRG1190-B	3.7
MRG1900-□	MRG1900-B	7.1

## Specifications : Removable Pre-Roller (With Stand)

### MRG1190-□

Model No.	Weight (kg)	Number of Rollers	Die Travel to Stop L (mm)	Max. Loading Weight each (kg) <sup>※1</sup>
MRG1190-710	14.8	11	710	3575
MRG1190-800	16.5	12	800	3150
MRG1190-850	17.5	13	850	2975
MRG1190-900	18.8	14	900	2800
MRG1190-950	19.6	14	950	2650
MRG1190-1000	20.5	15	1000	2500
MRG1190-1250	25.5	19	1250	2000
MRG1190-1600	32.6	24	1600	1550
MRG1190-2000	40.7	30	2000	1230

### MRG1900-□

Model No.	Weight (kg)	Number of Rollers	Die Travel to Stop L (mm)	Max. Loading Weight each (kg) <sup>※1</sup>
MRG1900-1000	29.6	15	1000	4915
MRG1900-1250	37.2	18	1250	3900
MRG1900-1600	47.7	24	1600	3050
MRG1900-2000	59.8	30	2000	2400

#### Note

- ※1. The maximum loading weight per pre-roller with a uniform load at the center of die travel L and 70 % length of the die travel L.

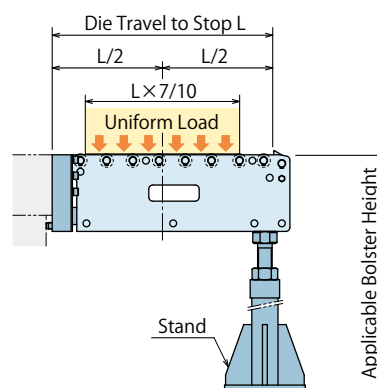

## Specifications : Stand

Model No.	Weight (kg)	Applicable Bolster Height (mm)	
		When using MRG1190-□	When using MRG1900-□
MRH0400-A	14.1	520 ~ 620	590 ~ 690
MRH0500-A	14.7	620 ~ 720	690 ~ 790
MRH0600-A	15.3	720 ~ 820	790 ~ 890
MRH0700-A	15.9	820 ~ 920	890 ~ 990
MRH0800-A	16.5	920 ~ 1020	990 ~ 1090
MRH0900-A	17.1	1020 ~ 1120	1090 ~ 1190
MRH1000-A	17.7	1120 ~ 1220	1190 ~ 1290

#### Note

- MRG Pre-Roller, MRG-B Mounting Block and MRH Stand are sold separately. Order by type and number required.

#### Notes on Handling

- MRH Stand can be used only for MRG Pre-Roller. Do not use it for any other use. (Cannot be used for MRC or MRD Pre-Roller.)
- When setting MRH Stand, make sure it is vertical to the floor.
- Fix MRH Stand to the floor and make sure MRG Pre-Roller is level.
- Do not adjust bolts beyond the maximum adjusting height.

#### Notes on Installation

- The floor should be level.
- The floor should be strong enough to support the maximum die weight (5.25N/mm<sup>2</sup>).
  - If the floor is made of concrete or mortar, set a base plate such as an iron plate in order to withstand load.
  - When MRH Stand is set on the pit cover, set joists or poles just under the cover to support the stand.
- MRH Stand has to be fixed to the floor.



External Dimensions : Removable Pre-Roller (With Stand) (MRG1190-□)

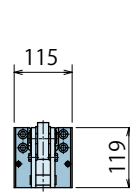
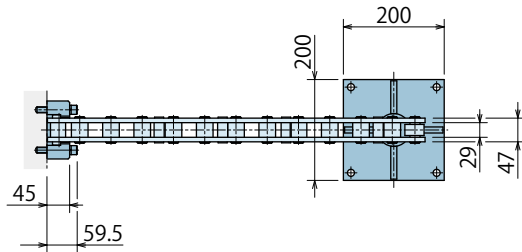

View A

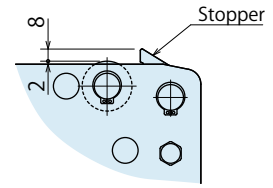

Enlarged View of B (Front End)

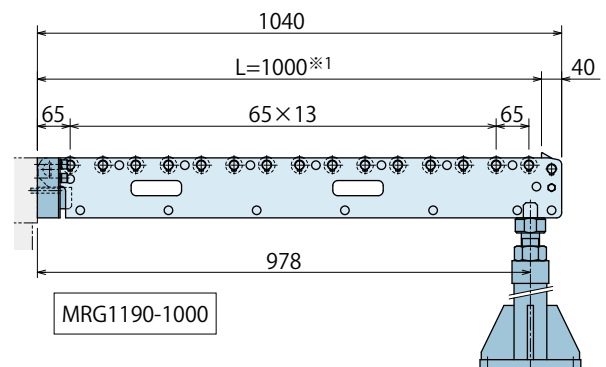
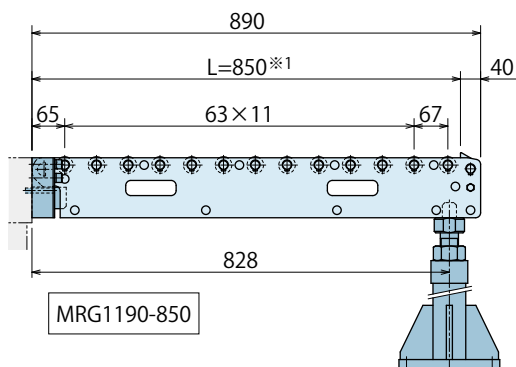
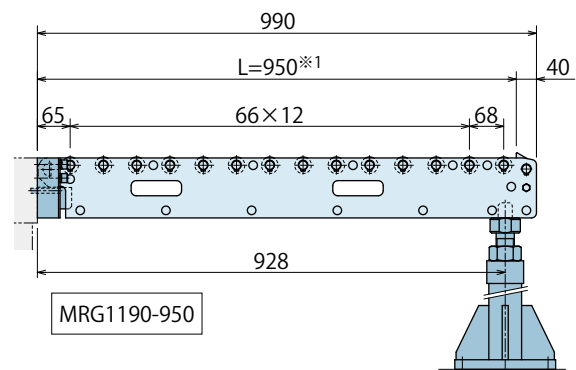
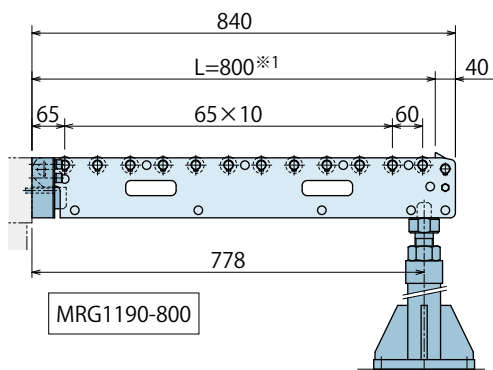
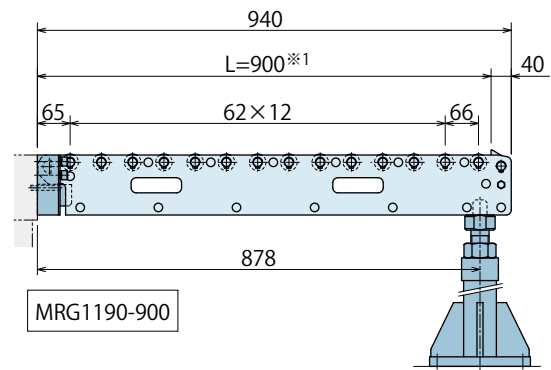
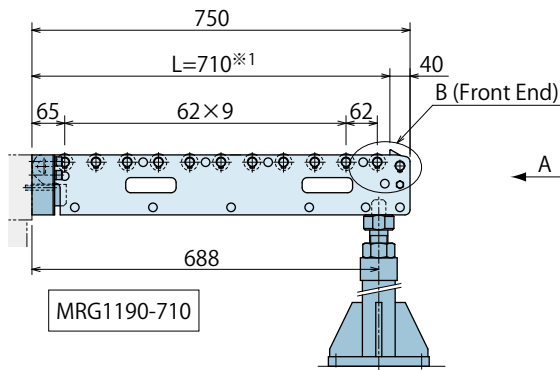

Note

※1. Indicates the die travel L.

External Dimensions : Mounting Block (MRG1190-B) Machining Dimension of Block Mounting Area

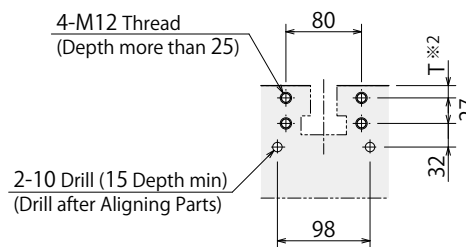
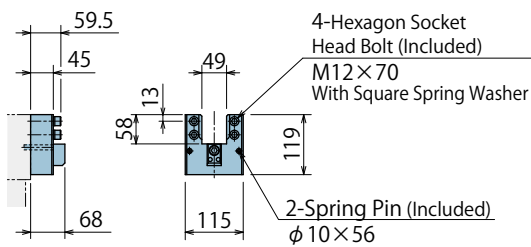

(mm)

RA Die Lifter		Dimension T <sup>※2</sup>
Model	Lift-Up Stroke	
RA018	1.5	13.5
RA022		
RA028	2	13
RA050		

Note

※2. Dimension T should be processed according to RA Die Lifter which is used with the block.

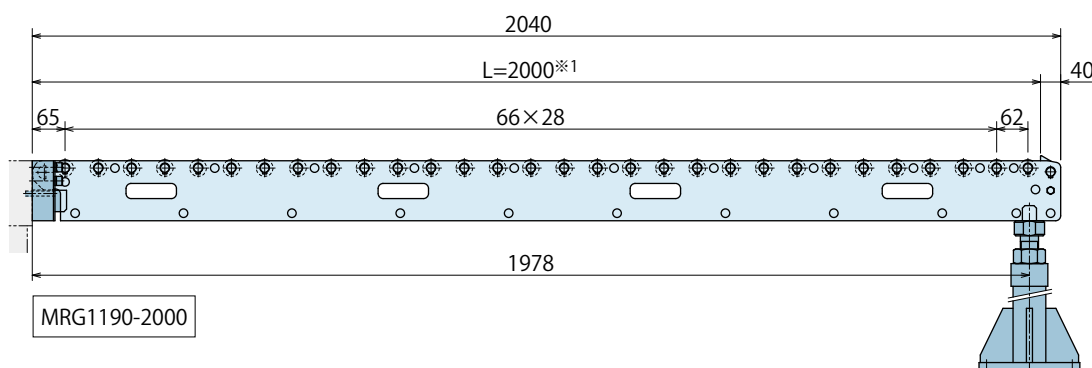
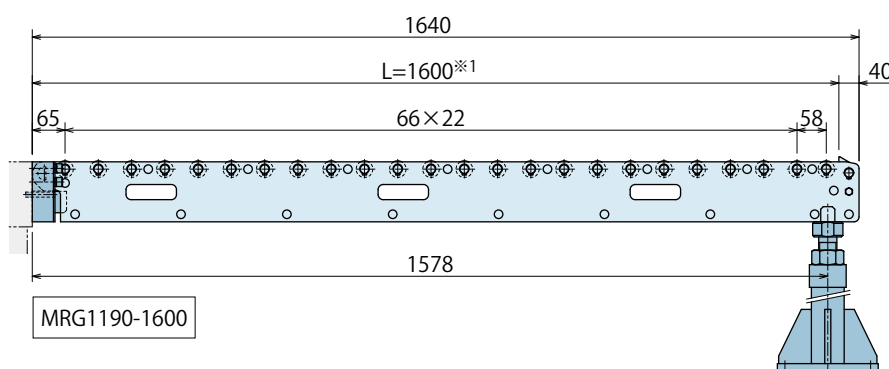
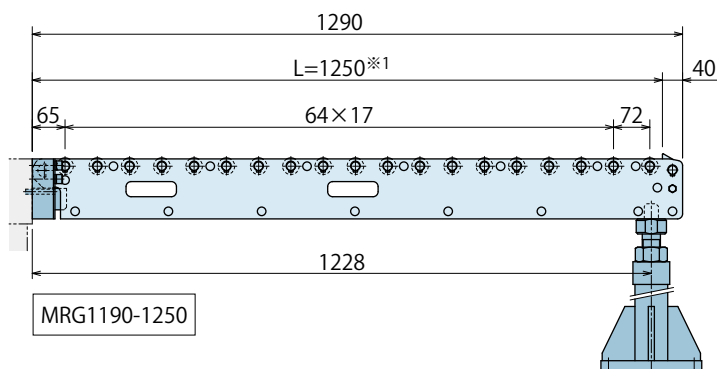

Clamp  
Hydraulic Unit  
Operation Control Panel

Die Lifter  
Pre-Roller

Accessories

Cautions  
Company Profile

Die Lifter

RA

RB

Pre-Roller

MRC

MRD

MRE/MRF

MRG

MRJ/MRK

External Dimensions : Removable Pre-Roller (With Stand) (MRG1900-□)

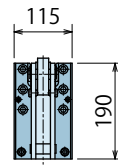

View A

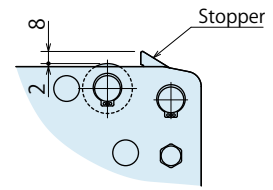

Enlarged View of B (Front End)

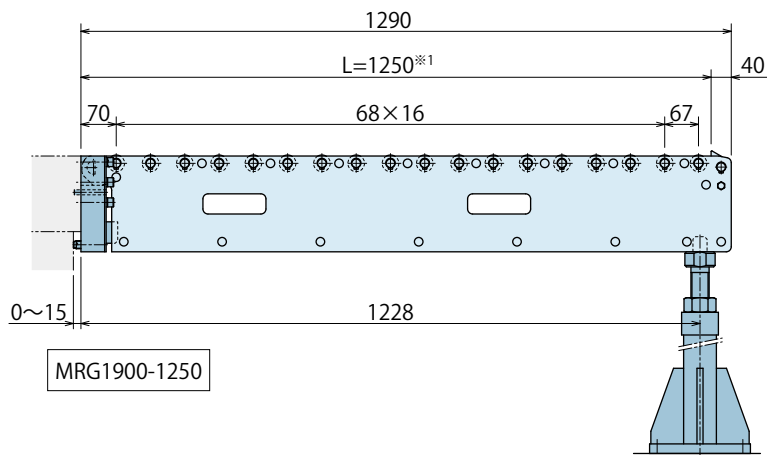
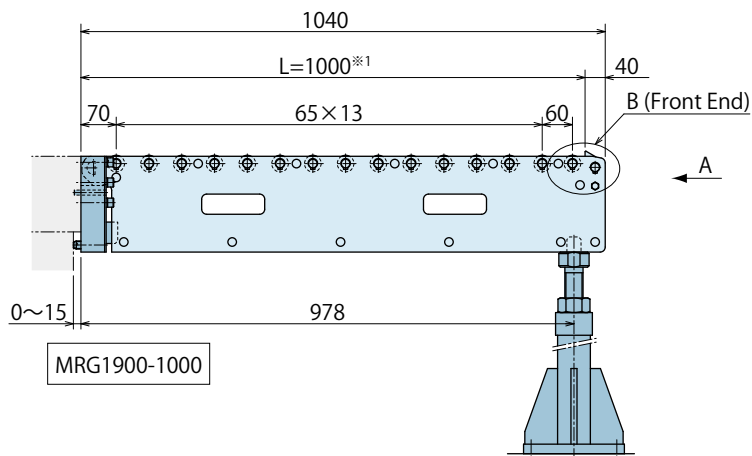
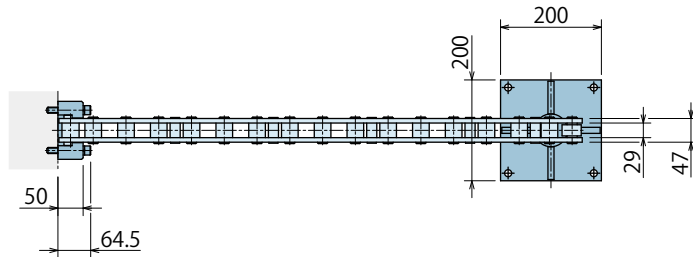

Note

※1. Indicates the die travel L.

External Dimensions : Mounting Block (MRG1900-B)    Machining Dimension of Block Mounting Area

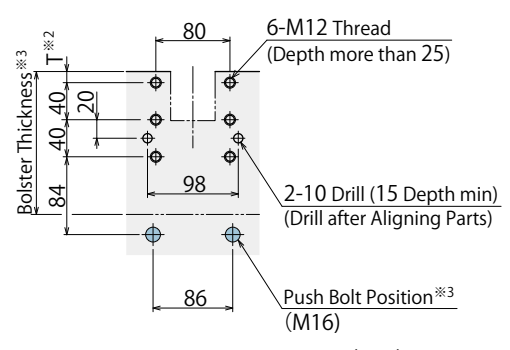
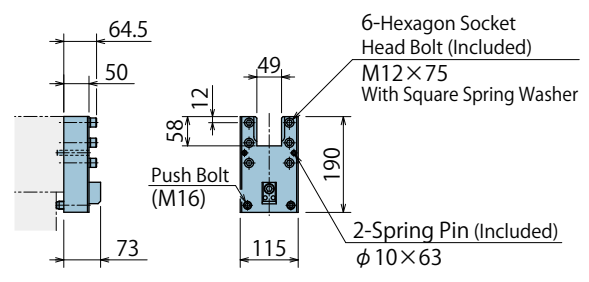

(mm)

RA Die Lifter		Dimension T <sup>※2</sup>
Model	Lift-Up Stroke	
RA018	1.5	12.5
RA022		
RA028	2	12
RA050		

Notes

- ※2. Dimension T should be processed according to RA Die Lifter which is used with the block.
- ※3. Use a push bolt when the bolster thickness is 160mm or less.

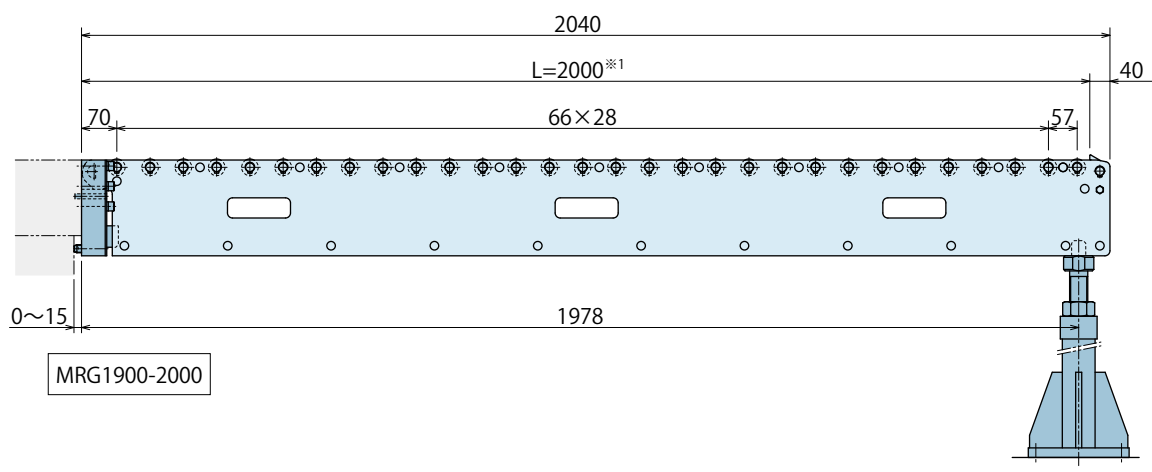
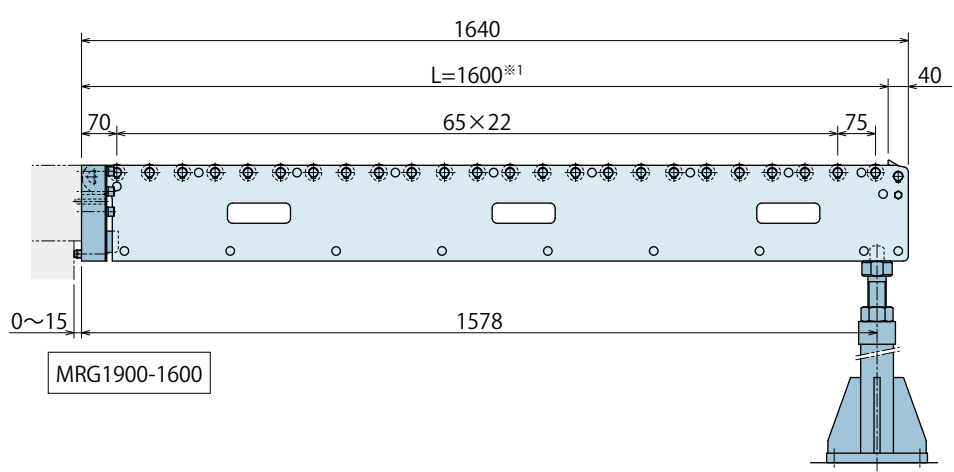

- Clamp Hydraulic Unit Operation Control Panel
- Die Lifter Pre-Roller**
- Accessories
- Cautions Company Profile
- Die Lifter
  - RA
  - RB
- Pre-Roller**
  - MRC
  - MRD
  - MRE/MRF
  - MRG**
  - MRJ/MRK

External Dimensions : Stand (For MRG Removable Pre-Roller)

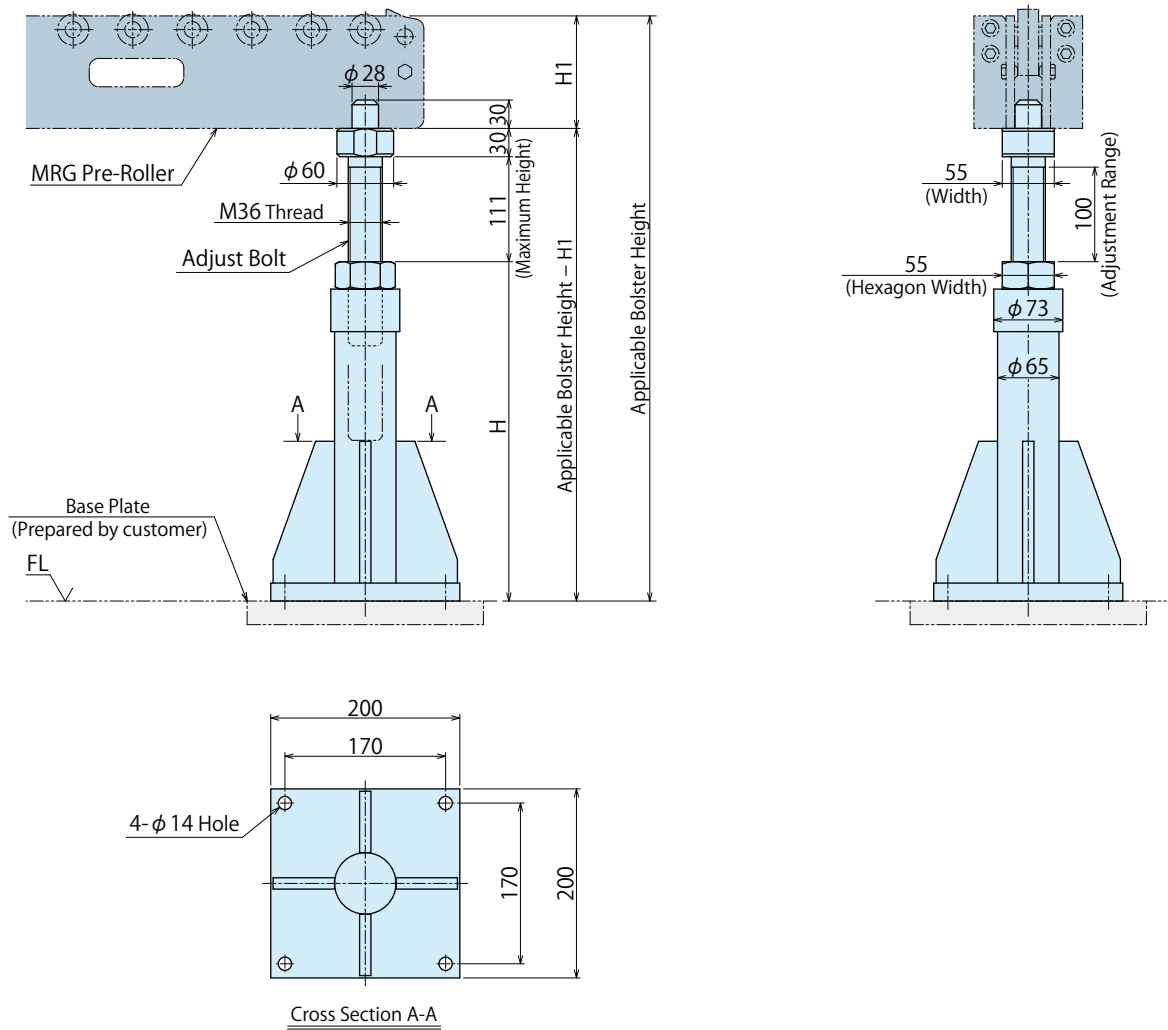

External Dimension List

Model	Applicable Bolster Height (mm)		H (mm)	H1 (mm)	
	For MRG1190-□	For MRG1900-□		For MRG1190-□	For MRG1900-□
MRH0400-A	520 ~ 620	590 ~ 690	359	119	190
MRH0500-A	620 ~ 720	690 ~ 790	459		
MRH0600-A	720 ~ 820	790 ~ 890	559		
MRH0700-A	820 ~ 920	890 ~ 990	659		
MRH0800-A	920 ~ 1020	990 ~ 1090	759		
MRH0900-A	1020 ~ 1120	1090 ~ 1190	859		
MRH1000-A	1120 ~ 1220	1190 ~ 1290	959		

 **MEMO**

Clamp  
Hydraulic Unit  
Operation Control Panel

**Die Lifter  
Pre-Roller**

Accessories

Cautions  
Company Profile

Die Lifter

RA

RB

**Pre-Roller**

MRC

MRD

MRE/MRF

**MRG**

MRJ/MRK

Model No. Indication : Horizontal Folding Pre-Roller (With Stand)

**MR J 295 0 - 800**

1
2
3
4

**1 Frame Storage Type**

- C : Removable Type \_\_\_\_\_ P.093
- D : Removable+Vertical Folding Type \_\_\_\_\_ P.103
- E : Horizontal Folding Type (Inside Arm) \_\_\_\_\_ P.113
- F : Horizontal Folding Type (Outside Arm) \_\_\_\_\_ P.113
- G : Removable Type (With Stand) \_\_\_\_\_ P.121
- J : Horizontal Folding Type (With Stand) (Inside Arm) \_\_\_\_\_ P.129
- K : Horizontal Folding Type (With Stand) (Outside Arm) \_\_\_\_\_ P.129



**2 Mounting Part Height (Pre-Roller Height)**

295 : Mounting Part Height 295mm

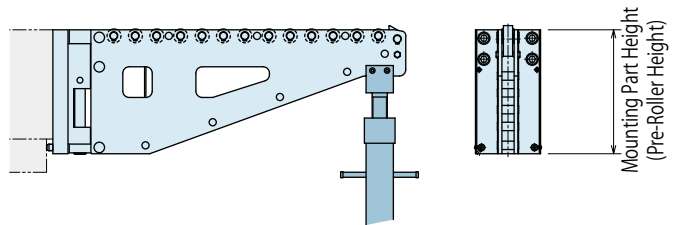

**3 Design No.**

0 : Revision Number

**4 Die Travel L**

**Dimensions** : Die Travel L  
 (Distance that the die can be pulled out)  
 (Please refer to the specifications)

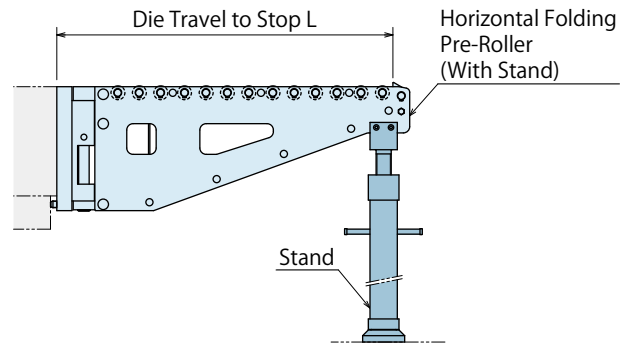

Model No. Indication : Stand

**MRL 060 0 - A**

1
2

**1 Applicable Bolster Height**

- 060 : Applicable Bolster Height 710 ~ 810 mm
- 070 : Applicable Bolster Height 810 ~ 910 mm
- 080 : Applicable Bolster Height 910 ~ 1010 mm
- 090 : Applicable Bolster Height 1010 ~ 1110 mm
- 100 : Applicable Bolster Height 1110 ~ 1210 mm
- 110 : Applicable Bolster Height 1210 ~ 1310 mm
- 120 : Applicable Bolster Height 1310 ~ 1410 mm

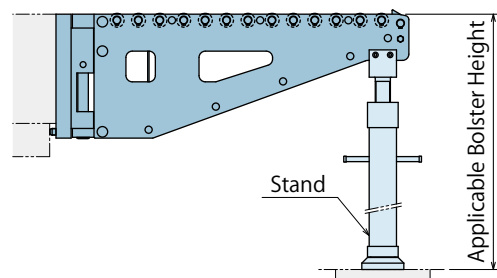

**2 Design No.**

0 : Revision Number

## Specifications : Horizontal Folding Pre-Roller (With Stand)

MRJ			MRK			Die Travel to Stop L (mm)	Max. Loading Weight each (kg) <sup>※1</sup>
Model No.	Weight (kg)	Number of Rollers	Model No.	Weight (kg)	Number of Rollers		
MRJ2950-800	44.5	13	MRK2950-800	47.8	13	800	4915
MRJ2950-900	47.6	15	MRK2950-900	51.2	15	900	4100
MRJ2950-1000	50.3	17	MRK2950-1000	54.0	17	1000	3550
MRJ2950-1250	56.6	22	MRK2950-1250	60.5	22	1250	2675

### Note

- ※1. The maximum loading weight per pre-roller with a uniform load at the center of die travel L and 70 % length of the die travel L.

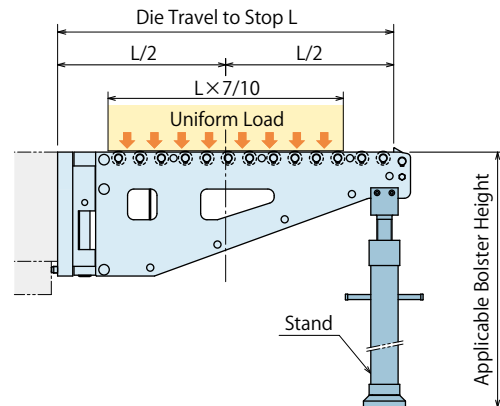

## Specifications : Stand

Model No.	Weight (kg)	Applicable Bolster Height (mm)
MRL0600-A	7.7	710 ~ 810
MRL0700-A	8.3	810 ~ 910
MRL0800-A	8.9	910 ~ 1010
MRL0900-A	9.5	1010 ~ 1110
MRL1000-A	10.1	1110 ~ 1210
MRL1100-A	10.7	1210 ~ 1310
MRL1200-A	11.3	1310 ~ 1410

### Notes on Handling

1. MRL Stand can be used only for MRJ / MRK Pre-Roller. Do not use it for any other use. (Cannot be used for MRE or MRF Pre-Roller.)
2. When setting MRL Stand, make sure it is vertical to the floor.
3. Adjust MRL Stand to the floor.
4. Do not adjust bolts beyond the maximum adjusting height.
5. Do not operate a press machine when MRJ, MRK Pre-Roller are stowed on the floor with MRL Stand.  
The vibration of press machine could damage the pre-roller.

### Notes on Installation

1. The floor should be level.
2. The floor should be strong enough to support the maximum die weight (5.25N/mm<sup>2</sup>).  
(1) If the floor is made of concrete or mortar, set a base plate such as an iron plate in order to withstand load.  
(2) When MRL Stand is set on the pit cover, set joists or poles just under the cover to support the stand.

## Folding Method

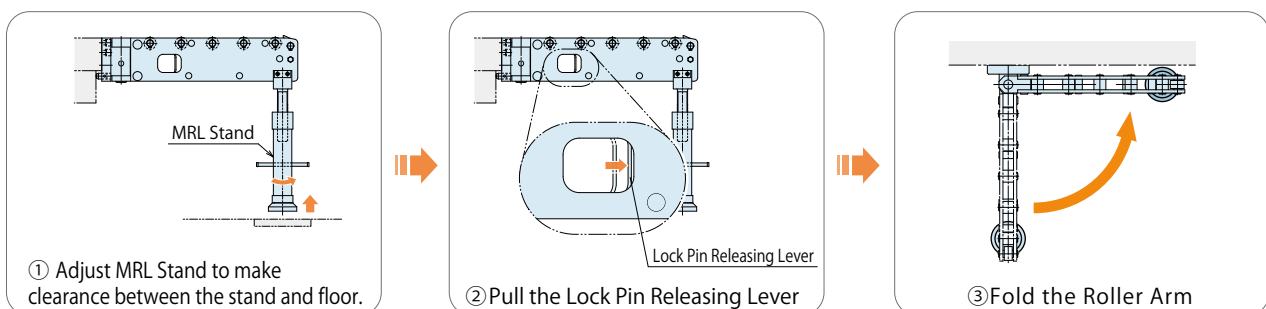

※. Can be folded to the other side as well.



External Dimensions : Horizontal Folding Pre-Roller (With Stand) (MRJ/MRK2950-□)

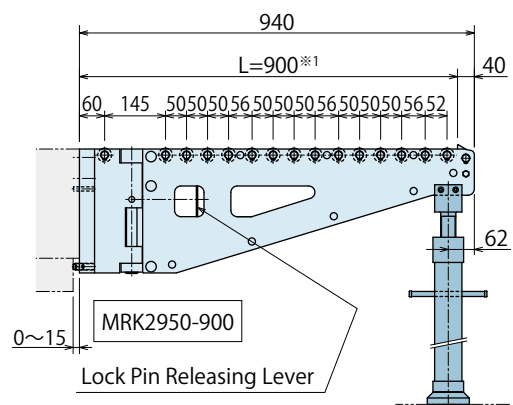
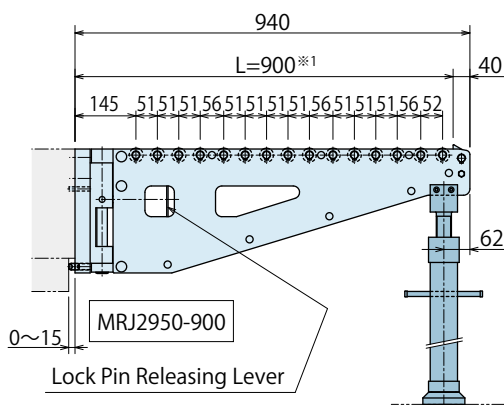
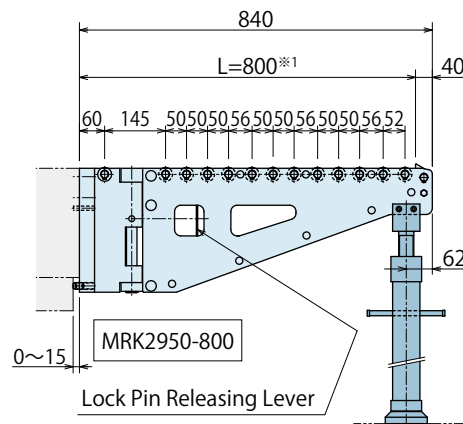
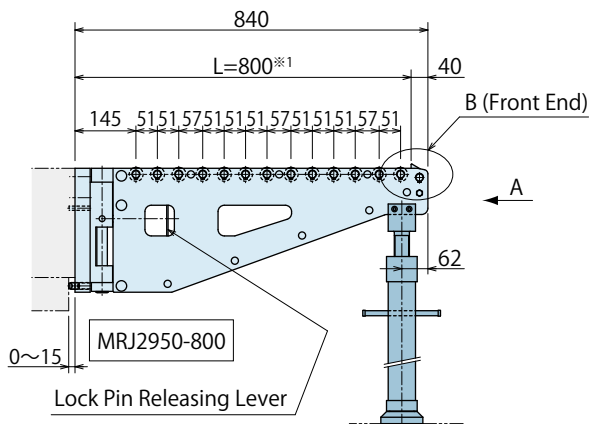
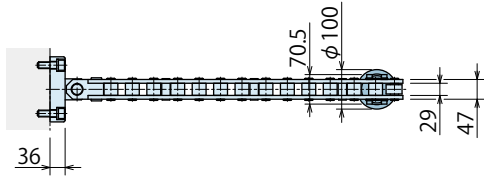
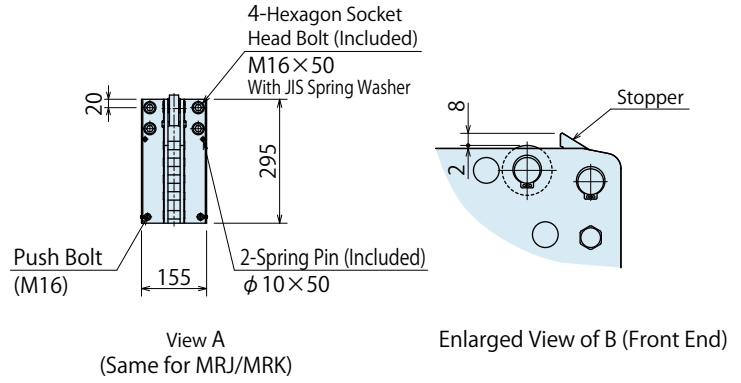

Note  
 ※1. Indicates the die travel L.

● Dimension when Folded

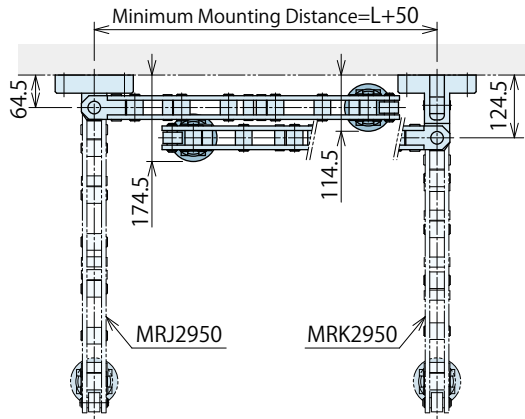

MRJ/MRK can swing to both left and right.

● Machining Dimension of Block Mounting Area

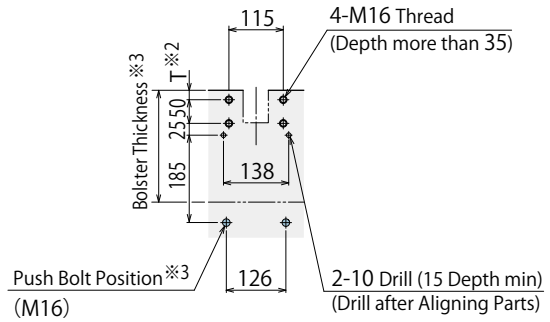

RA Die Lifter		(mm)
Model	Lift-Up Stroke	Dimension T*2
RA018	1.5	20.5
RA022		
RA028	2	20
RA050		

Notes

- \*2. Dimension T should be processed according to RA Die Lifter which is used with the block.
- \*3. Use a push bolt when the bolster thickness is 245mm or less.

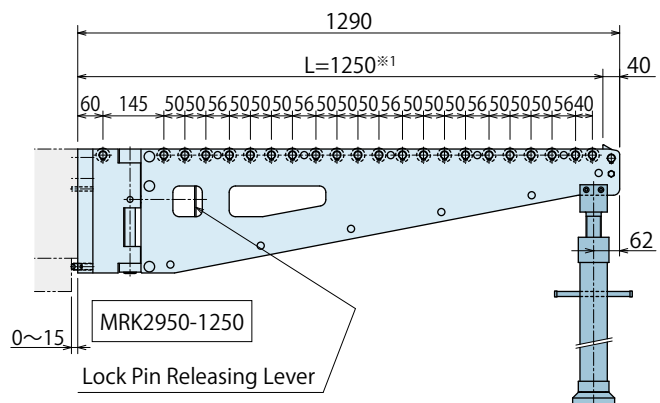
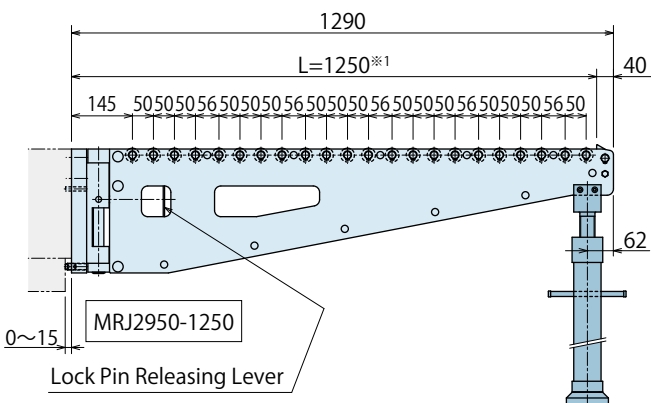
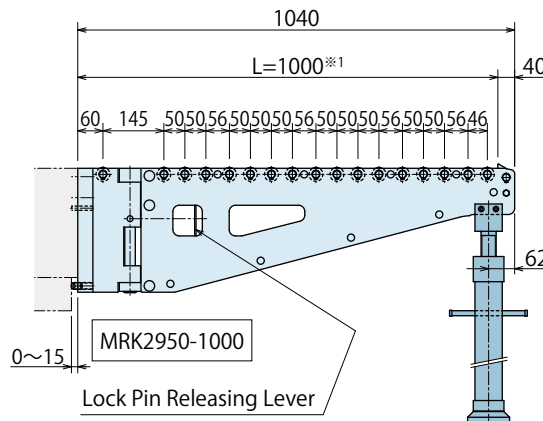
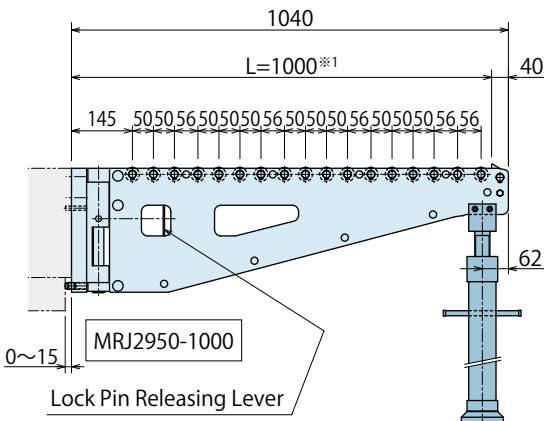

Clamp  
Hydraulic Unit  
Operation Control Panel

Die Lifter  
Pre-Roller

Accessories

Cautions  
Company Profile

Die Lifter

RA

RB

Pre-Roller

MRC

MRD

MRE/MRF

MRG

MRJ/MRK

External Dimensions : Stand (For MRJ/MRK Horizontal Folding Pre-Roller)

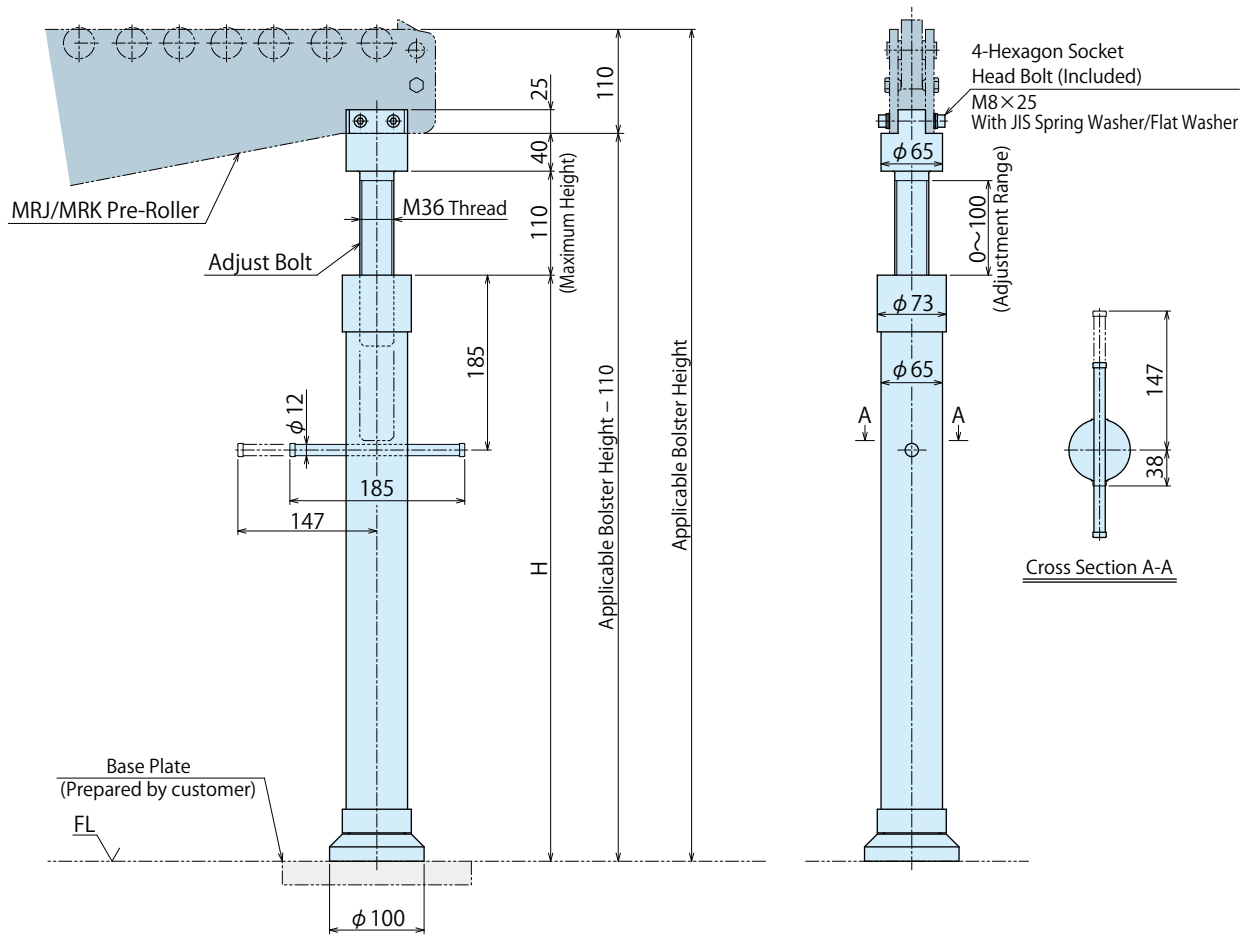

External Dimension List

Model	Applicable Bolster Height (mm)	H (mm)
MRL0600-A	710 ~ 810	550
MRL0700-A	810 ~ 910	650
MRL0800-A	910 ~ 1010	750
MRL0900-A	1010 ~ 1110	850
MRL1000-A	1110 ~ 1210	950
MRL1100-A	1210 ~ 1310	1050
MRL1200-A	1310 ~ 1410	1150

 **MEMO**

Clamp  
Hydraulic Unit  
Operation Control Panel

**Die Lifter  
Pre-Roller**

Accessories

Cautions  
Company Profile

Die Lifter

RA

RB

**Pre-Roller**

MRC

MRD

MRE/MRF

MRG

**MRJ/MRK**

## Accessories : Spacer Block

When setting pipe lines of die lifter on the pre-roller side (die loading side) when using pre-roller and die lifter, the spacer block can provide clearance for pipe lines between bolster and pre-roller.

### Model No. Indication

**MR C 119 0 - S**

1
2
3

### 1 Compatible Pre-Roller

**C** : For Removable Pre-Roller (MRC/MRD/MRG)

**E** : For Horizontal Folding Pre-Roller (MRE/MRF/MRJ/MRK)

### 2 Compatible Pre-Roller Height

**075** : Compatible Pre-Roller Height 75 mm

**190** : Compatible Pre-Roller Height 190 mm

**119** : Compatible Pre-Roller Height 119 mm

**295** : Compatible Pre-Roller Height 295 mm

**150** : Compatible Pre-Roller Height 150 mm

### 3 Design No.

**0** : Revision Number

### External Dimensions

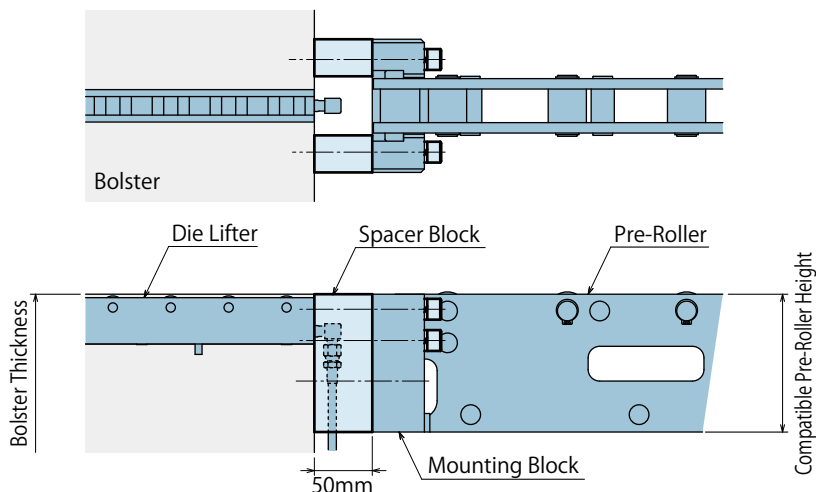

Spacer Block Model No.	Compatible Pre-Roller Model No.	Mounting Block Model No. <sup>※1</sup>
MRC0750-S	MRC0750-□	MRC0750-B
	MRD0750-□	MRD0750-B
MRC1190-S	MRC1190-□	MRC1190-B
	MRD1190-□	MRD1190-B
	MRG1190-□	MRG1190-B
MRC1500-S	MRC1500-□	MRC1500-B
	MRD1500-□	MRD1500-B
MRC1900-S	MRC1900-□	MRC1900-B
	MRD1900-□	MRD1900-B
	MRG1900-□	MRG1900-B
MRE1190-S	MRE1190-□	
	MRF1190-□	
MRE1900-S	MRE1900-□	
	MRF1900-□	
MRE2950-S	MRE2950-□	
	MRF2950-□	
	MRJ2950-□	
	MRK2950-□	

#### Notes

※1. Horizontal folding pre-roller (MRE, MRF, MRJ, MRK) is a united type of pre-roller and mounting block, thus mounting block is included.

1. The option of die lifter should be G : pin specifications and hose fitting should be mounted directly to die lifter.

When using pipe nipple, be careful with the length of pipe nipple and the mounting point of die lifter.

2. Bolster thickness should be thicker than the spacer block.

## Accessories : End Plate

When setting pipe lines of die lifter on opposite side of the pre-roller (die loading side) when using pre-roller and die lifter, the end plate prevents die lifter from coming out of the bolster to pre-roller side.

### Model No. Indication

# MRC 119 0 - E

1

2

## 1 Compatible Pre-Roller Height

**075** : Compatible Pre-Roller Height 75 mm

**119** : Compatible Pre-Roller Height 119 mm

**150** : Compatible Pre-Roller Height 150 mm

**190** : Compatible Pre-Roller Height 190 mm

## 2 Design No.

**0** : Revision Number

### External Dimensions

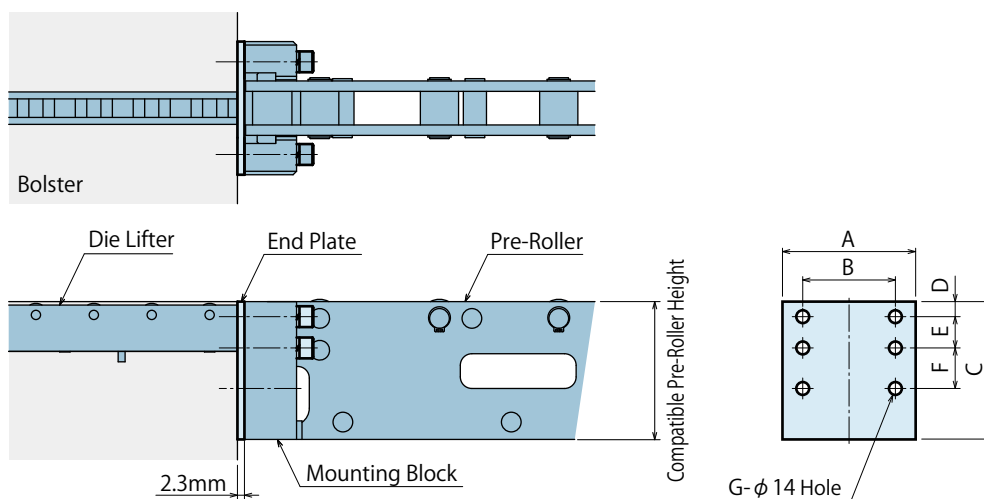

(mm)

End Plate Model No.	Pre-Roller Model No. <sup>※2</sup>	Mounting Block Model No. <sup>※2</sup>	A	B	C	D	E	F	G
MRC0750-E	MRC0750-□	MRC0750-B	96	70	75	13			2
	MRD0750-□	MRD0750-B							
MRC1190-E	MRC1190-□	MRC1190-B	115	80	119	13	27		4
	MRD1190-□	MRD1190-B							
	MRG1190-□	MRG1190-B							
MRC1500-E	MRC1500-□	MRC1500-B	115	80	150	13	27		4
	MRD1500-□	MRD1500-B							
MRC1900-E	MRC1900-□	MRC1900-B	115	80	190	12	40	40	6
	MRD1900-□	MRD1900-B							
	MRG1900-□	MRG1900-B							

Note

※2. End plate can be used for mounting block of removable pre-roller (MRC/MRD/MRG).

Horizontal folding pre-roller (MRE, MRF, MRJ, MRK) does not require end plate, since the mounting block part works as end plate.

**Cautions**

● Notes for Design

- 1) Check the specifications.
  - Please use each product according to the specifications.
- 2) Check the die weight.
  - Make sure the die weight is less than the maximum loading weight.
- 3) Check the die dimensions.
  - Make sure that the length of the die from front to back is at least twice as long as the distance between the first roller of the die lifter (closest to the pre-roller) and the last roller of the pre-roller (closest to the die lifter).  
If the length of the die is less than double the distance between rollers, the transition will not be smooth, and it could result in damage to the die of equipment.

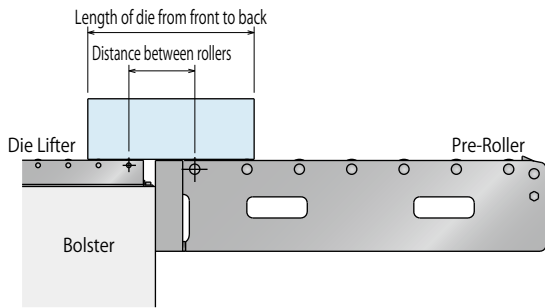

● Notes on Installation

- 1) Mounting the block
  - ① Secure the block to the edge of the bolster with attached mounting bolt.
  - ② Mount pre-roller and use shims to level the roller surface.
  - ③ With the die lifter inside the bolster in the lifted position, adjust the position of the mounting block so that the top of the rollers on the die lifter and pre-roller are level and then perform the final tightening of mounting bolts.

Model No.	Mounting Bolt Size	Tightening Torque (N·m)
MR□0750	M12	98
MR□1190		
MR□1500		
MR□1900		
MR□2950	M16	200

※ If rollers are not set in the bolster, adjust the roller surface of the pre-roller to be level with the bolster surface.

- ④ Be sure to position the block with a spring pin. Without a spring pin, the pre-roller could be misaligned, and the die could fall off the rollers.

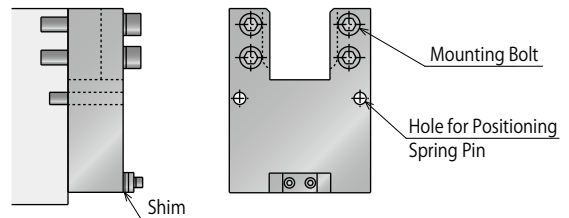

2) Level Adjustment

- Use shims to adjust the front end roller (roller A) of the pre-roller to be approximately 2mm higher than the bolster surface.

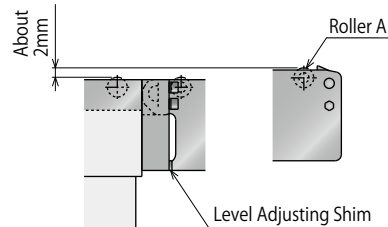

3) Mounting the hook (MRD roller only)

- Align the pin of the hook with the hole on the block and mount the hook with the attached mounting bolt.

Mounting Bolt Tightening Torque

Model No.	Mounting Bolt Size	Tightening Torque(N·m)
MRD0750	M12	98
MRD1190		
MRD1500		
MRD1900		

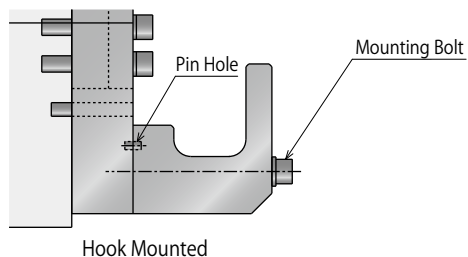
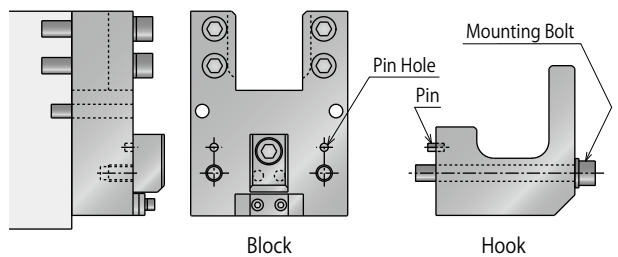

## ● Notes on Handling

- 1) It should be handled by qualified personnel.
- 2) The pre-roller should not be used for purposes other than die changes.
- 3) Only use dies that weigh less than the maximum load.
- 4) Stow the pre-roller away while operating the press machine.
  - Fold or remove the pre-roller while operating the press machine. If the press machine is operated with the pre-roller in place, the vibration could damage the pre-roller.
- 5) Check the stopper
  - If the die is moved with the stopper released, the die could drop and cause an injury, so always make sure the stopper is in place before use.

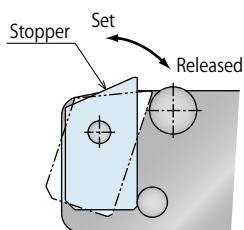

- 6) Do not exceed the maximum die lowering speed.
  - When placing the die on the pre-roller, lower it at a speed of 50mm/sec or less. If it is done too fast the pre-roller may be damaged and cause an injury.
- 7) Do not exceed the maximum die moving speed.
  - When moving die, do not exceed 100mm/sec in order to prevent damage to stopper.
- 8) Be careful not to injure your fingers when folding the frame.
  - Never let the pre-roller drop freely when removing or folding it as it may damage the equipment or cause an injury.
- 9) Check the lock pin (MRE/MRF/MRJ/MRK Only)
  - When moving the die, always ensure that the lock pin is engaged.
- 10) Secure the stand (MRG/MRJ/MRK Only)
  - Make sure the stand is fixed to the floor when moving the die.
- 11) Do not pour water or oil over the product.
  - It may lead to malfunction or deterioration of the product and cause an accident.

## ● Maintenance • Inspection

- 1) Removal of equipment
  - Before the equipment is removed, make sure that the preventive devices are in place.
  - Make sure there is no abnormality in the bolts and respective parts before restarting.
- 2) Check to make sure that the rollers move smoothly and do not make noises.
- 3) Please contact us for overhaul and repairs.
- 4) Make sure that the stopper returns to the normal position by spring force.
- 5) Make sure the die holds when the stopper is released.
- 6) Check the block mounting bolts periodically and tighten as needed.
- 7) Check the hook mounting bolts periodically and tighten as needed. (MRD Only)
- 8) When using a push bolt, make sure there is no space between the push bolt and the press.

※ Refer to P.145 for common cautions.

• Notes on Handling • Maintenance / Inspection • Warranty



## ● Cautions

### ● Notes on Installation (Cautions for Hydraulic Series)

#### 1) Check the fluid to use

- Please use the appropriate fluid by referring to the Hydraulic Fluid List.
- If hydraulic oil with viscosity grade higher than ISO-VG-32 is used, action time would be longer.
- If using it at low temperature, action time will be longer because the viscosity of hydraulic oil becomes higher.

#### 2) Procedure before piping

- The pipeline, piping connector and fixture circuits should be cleaned by thorough flushing.
- The dust and cutting chips in the circuit may lead to fluid leakage and malfunction.
- Our products except some valves are not equipped with protective function to prevent dust and cutting chips going into the hydraulic system and pipeline.

#### 3) Applying sealing tape

- Wrap with tape 1 to 2 times following the screwing direction.
- Pieces of the sealing tape can lead to air leaks and malfunction.
- In order to prevent a foreign substance from going into the product during piping, it should be carefully cleaned.

#### 4) Air bleeding in the hydraulic circuit

- If the hydraulic circuit has excessive air, the action time may become very long.  
After installing the hydraulic circuit, or if the pump run out of oil, be sure to bleed air by the following step.
- ① Reduce hydraulic supply pressure to less than 2MPa.
- ② Please loosen the cap nut of pipe fitting that is closest to clamps · RA die lifters by one full turn.
- ③ Wiggle the pipeline to loosen the outlet of pipeline fitting.  
The hydraulic fluid mixed with air comes out.

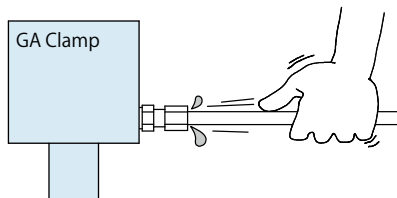

- ④ Tighten the cap nut after bleeding.
- ⑤ It is more effective to bleed air at the highest point inside the circuit or at the end of the circuit.

#### 5) Checking looseness and retightening

- At the beginning of the machine installation, the bolt/nut may be tightened lightly.  
Check torque and re-tighten as required.

### ● Hydraulic Fluid List

Maker	ISO Viscosity Grade ISO-VG-32	
	Anti-Wear Hydraulic Oil	Multi-Purpose Hydraulic Oil
Showa Shell Sekiyu	Tellus S2 M 32	Morlina S2 B 32
Idemitsu Kosan	Daphne Hydraulic Fluid 32	Daphne Super Multi Oil 32
JX Nippon Oil & Energy	Super Hyrando 32	Super Mulpus DX 32
Cosmo Oil	Cosmo Hydro AW32	Cosmo New Mighty Super 32
ExxonMobil	Mobil DTE 24	Mobil DTE 24 Light
Matsumura Oil	Hydol AW-32	
Castrol	Hyspin AWS 32	

Note As it may be difficult to purchase the products as shown in the table from overseas, please contact the respective manufacturer.

## ● Speed Control Circuit of Hydraulic Cylinder and Notes



If the hydraulic cylinder speed is controlled, the circuit should be designed with the following points taken into consideration. Review these notes prior to installation as the wrong circuit design may lead to machine malfunction and damage.

### ● Flow control circuit for single acting cylinder.

For spring return type single acting cylinders, restricting flow during release can extremely slow down or prevent release action. The preferred method is to control the flow during the lock action and use a valve that has free-flow in the release direction. Also, it is preferred to provide a flow control valve at each actuator.

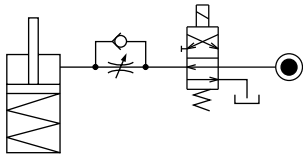

If the release action is accelerated by excessive hydraulic flow the cylinder may sustain damage. In this case add flow control to regulate flow.

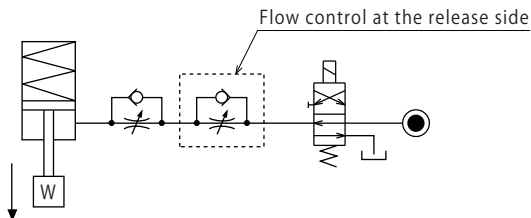

### ● Flow control circuit for double acting cylinder.

Flow control circuit for double acting cylinder should have meter-out circuits for both the lock and release sides. Meter-in control can have adverse effect by presence of air in the system.

#### 【Meter-out circuit】

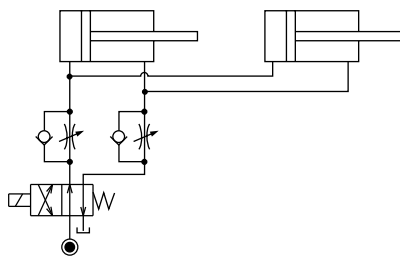

#### 【Meter-in circuit】

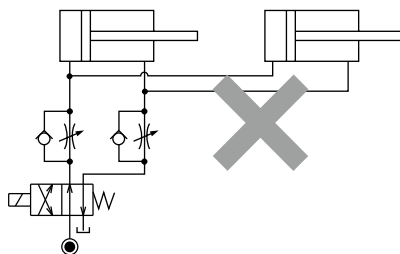

In the case of meter-out circuit, the hydraulic circuit should be designed with the following points.

- ① Single acting components should not be used in the same flow control circuit as the double acting components. The release action of the single acting cylinders may become erratic or very slow.

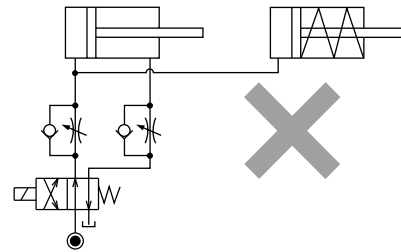

Refer to the following circuit when both the single acting cylinder and double acting cylinder are used together.

- Separate the control circuit.

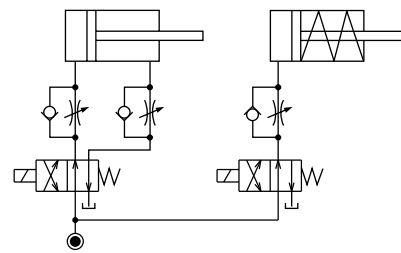

- Reduce the influence of double acting cylinder control unit. However, due to the back pressure in tank line, single action cylinder is activated after double action cylinder work.

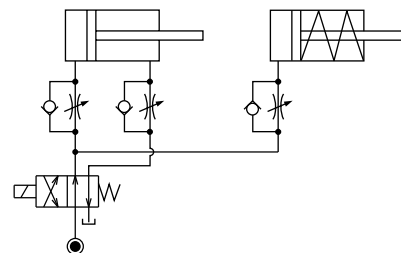

- ② In the case of meter-out circuit, the inner circuit pressure may increase during the cylinder action because of the fluid supply. The increase of the inner circuit pressure can be prevented by reducing the supplied fluid beforehand via the flow control valve. Especially when using sequence valve or pressure switches for clamping detection, if the back pressure is more than the set pressure then the system will not work as it is.

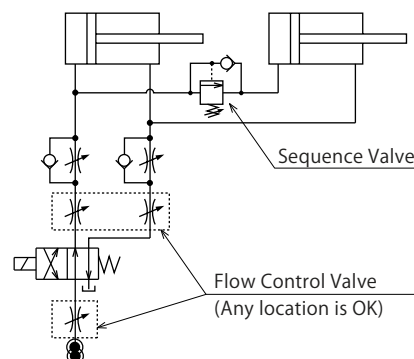

## ● Cautions

### ● Notes on Handling

- 1) It should be handled by qualified personnel.
  - The hydraulic machine / air compressor should be handled and maintained by qualified personnel.
- 2) Do not handle or remove the machine unless the safety is ensured.
  - ① The machine and equipment can only be inspected or prepared when it is confirmed that the preventive devices are in place.
  - ② Before the machine is removed, make sure that the above-mentioned safety measures are in place. Shut off the air of hydraulic source and make sure no pressure exists in the hydraulic and air circuit.
  - ③ After stopping the machine, do not remove until the temperature cools down.
  - ④ Make sure there is no abnormality in the bolts and respective parts before restarting the machine or equipment.
- 3) Do not touch clamps (cylinders) while they are working. Otherwise, your hands may be injured.

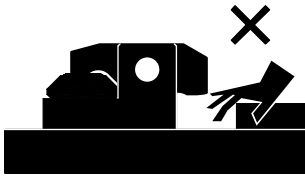

- 4) Do not disassemble or modify it.
  - If the equipment is taken apart or modified, the warranty will be void even within the warranty period.

### ● Maintenance • Inspection

- 1) Removal of the machine and shut-off of pressure source
  - Before the machine is removed, make sure that the above-mentioned safety measures are in place. Shut off the air of hydraulic source and make sure no pressure exists in the hydraulic and air circuit.
  - Make sure there is no abnormality in the bolts and respective parts before restarting.
- 2) Regularly clean the area around the equipment.
  - If it is used when the surface is contaminated with dirt, it may lead to packing seal damage, malfunctioning, fluid leakage and air leaks.

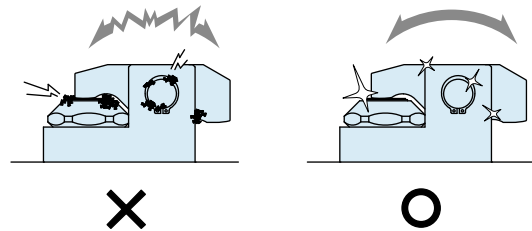

- 3) If disconnecting by couplers on a regular basis, air bleeding should be carried out daily to avoid air mixed in the circuit.
- 4) Regularly tighten bolts and pipe line, mounting bolts, nuts, circlips and cylinders to ensure proper use.
- 5) Make sure the hydraulic fluid has not deteriorated.
- 6) Make sure there is smooth action and no abnormal noise.
  - Especially when it is restarted after left unused for a long period, make sure it can be operated properly.
- 7) The products should be stored in the cool and dark place without direct sunshine or moisture.
- 8) Please contact us for overhaul and repair.

## ● Warranty

### 1) Warranty period

- The product warranty period is 18 months from shipment from our factory or 12 months from initial use, whichever is earlier.

### 2) Warranty scope

- If the product is damaged or malfunctions during the warranty period due to faulty design, materials or workmanship, we will replace or repair the defective part at our expense. Defects or failures caused by the following are not covered.

- ① If the stipulated maintenance and inspection are not carried out.
- ② If the product is used while it is not suitable for use based on operator judgment, resulting in defect.
- ③ If it is used or handled in inappropriate way by the operator. (Including damage caused by the misconduct of a third party.)
- ④ If the defect is caused by reasons other than our responsibility.
- ⑤ If repair or modifications are carried out by anyone other than Kosmek, or without our approval and confirmation, it will void warranty.
- ⑥ Defects caused by natural disasters or calamities not attributable to our company.
- ⑦ Parts expenses or replacement expenses due to parts consumption and deterioration. (Such as rubber, plastic, seal material and some electric components.)

Damages from direct result of a product defect shall be excluded from the warranty.

Clamp  
Hydraulic Unit  
Operation Control Panel

Die Lifter  
Pre-Roller

Accessories

Cautions  
Company Profile

#### Cautions

Notes on Installation  
(For Hydraulic Series)

Hydraulic Fluid List

Speed Control Circuit of  
Hydraulic Cylinder & Notes

Notes on Handling

Maintenance / Inspection

Warranty

#### Company Profile

Company Profile

Our Products

History

Sales Office

# Sales Office

## Sales Offices Across the World

Japan Overseas Sales	<b>TEL. +81-78-991-5162</b>	<b>FAX. +81-78-991-8787</b>
	KOSMEK LTD. 1-5, 2-chome, Murotani, Nishi-ku, Kobe-city, Hyogo, 651-2241, Japan 〒651-2241 兵庫県神戸市西区室谷2丁目1番5号	
USA KOSMEK (USA) LTD.	<b>TEL. +1-630-241-3465</b>	<b>FAX. +1-630-241-3834</b>
	1441 Branding Avenue, Suite 110, Downers Grove, IL 60515 USA	
China KOSMEK (CHINA) LTD. 考世美(上海)貿易有限公司	<b>TEL. +86-21-54253000</b>	<b>FAX. +86-21-54253709</b>
	21/F, Orient International Technology Building, No.58, Xiangchen Rd, Pudong Shanghai 200122., P.R.China 中国上海市浦东新区向城路58号东方国际科技大厦21F室 200122	
Thailand Thailand Representative Office	<b>TEL. +66-2-715-3450</b>	<b>FAX. +66-2-715-3453</b>
	67 Soi 58, RAMA 9 Rd., Suanluang, Suanluang, Bangkok 10250, Thailand	
Europe (Europe Exclusive Distributors) KOS-MECH GmbH	<b>TEL. +43-463-287587-10</b>	<b>FAX. +43-463-287587-20</b>
	Schleppeplatz 2 9020 Klagenfurt Austria	
Taiwan (Taiwan Exclusive Distributors) Full Life Trading Co., Ltd. 盈生貿易有限公司	<b>TEL. +886-2-82261860</b>	<b>FAX. +886-2-82261890</b>
	16F-4, No.2, Jian Ba Rd., Zhonghe District, New Taipei City Taiwan 23511 台湾新北市中和區建八路2號 16F-4 (遠東世紀廣場)	
Philippines (Philippines Exclusive Distributors) G.E.T. Inc, Phil.	<b>TEL.+63-2-310-7286</b>	<b>FAX. +63-2-310-7286</b>
	Victoria Wave Special Economic Zone Mt. Apo Building, Brgy. 186, North Caloocan City, Metro Manila, Philippines 1427	
Indonesia (Indonesia Exclusive Distributors) P.T PANDU HYDRO PNEUMATICS	<b>TEL.+62-21-5818632</b>	<b>FAX. +62-21-5814857</b>
	Ruko Green Garden Blok Z- II No.51 Rt.005 Rw.008 Kedoya Utara-Kebon Jeruk Jakarta Barat 11520 Indonesia	

## Sales Offices in Japan

Head Office Kansai Office Overseas Sales	<b>TEL. +81-78-991-5162</b>	<b>FAX. +81-78-991-8787</b>
	KOSMEK LTD. 1-5, 2-chome, Murotani, Nishi-ku, Kobe-city, Hyogo, 651-2241, Japan 〒651-2241 兵庫県神戸市西区室谷2丁目1番5号	
Kanto Office	<b>TEL. +81-48-652-8839</b>	<b>FAX. +81-48-652-8828</b>
	KOSMEK LTD. 81, 4-chome, Onari-cho, Kita-ku, Saitama City, Saitama, 331-0815, Japan 〒331-0815 埼玉県さいたま市北区大成町4丁目81番地	
Chubu Office	<b>TEL. +81-566-74-8778</b>	<b>FAX. +81-566-74-8808</b>
	KOSMEK LTD. 10-1, 2-chome, Misono-cho, Anjo City, Aichi, 446-0076, Japan 〒446-0076 愛知県安城市美園町2丁目10番地1	
Kyusyu Office	<b>TEL. +81-92-433-0424</b>	<b>FAX. +81-92-433-0426</b>
	KOSMEK LTD. 8-10-101, 1-chome, Kamimuta, Hakata-ku, Fukuoka City, Fukuoka, 812-0006, Japan 〒812-0006 福岡県福岡市博多区上牟田1丁目8-10-101	